



# 100 % Full Fresh Air Stand Alone Air Conditioner

**Packaged** Hybrid Indirect / Direct Evaporative Cooling Unit

**CG – HIDEC series**



### **Meet and Comply With**

- ASHRAE Standard 62.1
- ASHRAE Standard 90.1
- ASHRAE STD 143

- Highest Efficient Cooling Performance
- The Best Of IAQ "Indoor Air Quality"
- Cut Of Electricity up to 90 %
- Environment Friendly.
- Less Co2 Emissions
- Cost Effective Solution
- Superior Performance in Hot and Dry Climates
- Indoor and Outdoor Installation.
- Ready For Energy Recovery Applications.
- Anti Corrosive Construction.



## Packaged Hybrid Indirect / Direct Evaporative Cooling Unit

CG – HIDEc series

### Buildings / Owner Needs

All Building applications need fresh air to achieve the IAQ - Indoor Air Quality In according to the standard and code requirements.

S S Air Technology “Smart Sustainable Air Technology” present the new generation of Clima Green products of highly efficient 100 % Full Fresh Stand Alone HIDEc “Hybrid Indirect Direct Evaporative Cooling” Air Conditioning units.

The 100% full fresh air of HIDEc technology provide the highest cooling performance in comparing with the traditional

Indeed, IDEc as two stage Indirect / Direct evaporative cooling system provide significant running cost saving but still the IDEc cooling performance depend on the exchanger efficiency and the ambient conditions' air conditioning system.

The derive cooling force for the IDEc units is the outdoor ambient, the lower the outdoor dew point temperature, the much cooling could be achieved, Meanwhile and up to date, the most efficient worldwide IDEc products Insufficient enough to secure the desired leaving air condition as specified in 2019 - ASHRAE STD-62.1 for the maximum accepted dew point temperatures as 60 °F "15.5 °C".

So, supplement cooling source such as Dx “Direct Expansion” refrigeration system or CHW “Chilled Wate” shall be added to complement the cooling process to achieve the requested specified conditions or at least to secure the minimum leaving DP as 15.5 ° C.

### Why Clima Green HIDEc units??

Clima Geen units fulfill the buildings / Owner needs, it provides multi-Stages packaged Cooling units comprise Indirect / Direct Evaporative Cooling integrated with Dx-Compression circuits via CG-HIDEc series models fulfilling the ASHRAE Standard requirements, indoor thermal comfort, energy saving and environmental control.

### Benefit's

#### Four components of Indoor air quality and Thermal Comfort

- Ventilation:** Ensures the provision of full fresh air
- **Air Conditioning:** Delivers the right supply air temperature to achieve the indoor unit load
- **Humidification:** Ensures relative indoor humidity levels are respected
- **Filtration:** Separates pollen, dust and pollution odors that are harmful to individuals' health

#### Five Components for Energy Savings and Environmental Control

- **VFD motors:** Ensures the electricity cut bills specifically in part load operation.
- **Energy Recovery:** Delivers energy savings by transferring heat and moisture between airflows
- **Adiabatic Evaporative Condenser:** Maximizing the unit COP secure reliable and long lifetime of the refrigerant circuit's components.
- **Eco friendly Refrigerants: HFC** - refrigerants zero ODP, ensure low GWP as 1774 and lower CO2 emissions.
- **Economizer Mode:** Free Cooling by 100% outside air in according to the ambient air temperature and dew point with no need of refrigeration compression cycle or IDEc units, only supply/return fans shall in duty work.
- **Waste Water Management: Re-use** water condensation to enhance better cooling performance and avoid wastewater.

### CG-HIDEC series Construction Concept

Clima Geen CG-HIDEC units consist of two sections, fully separated as to independent air passage enclosures.

#### The first section "Primary Air"

Comprise the primary air supply fan, the IEC water cooling coil, the Dx-evaporator coil and evaporative cooling pad

#### The second section "Secondary Air"

Comprise the compressors, adiabatic evaporative cooling condenser coil as well as the evaporative cooling pads and recirculating pump.



### Primary Air Section

7	Outside Air
8	IEC Water coil
9	DX Evap Coil
10	DEC Wet pads
10a	DEC Wet pads pump
11	Supply Air Fan
12	Supply Air

### Secondary Air Section

1	Outside Air
2	Room Exhaust Air
3	IEC Wet Pads
3a	IEC pump
4	Condenser coil
5	Secondary Air Fan
6	Humid Exhaust Air

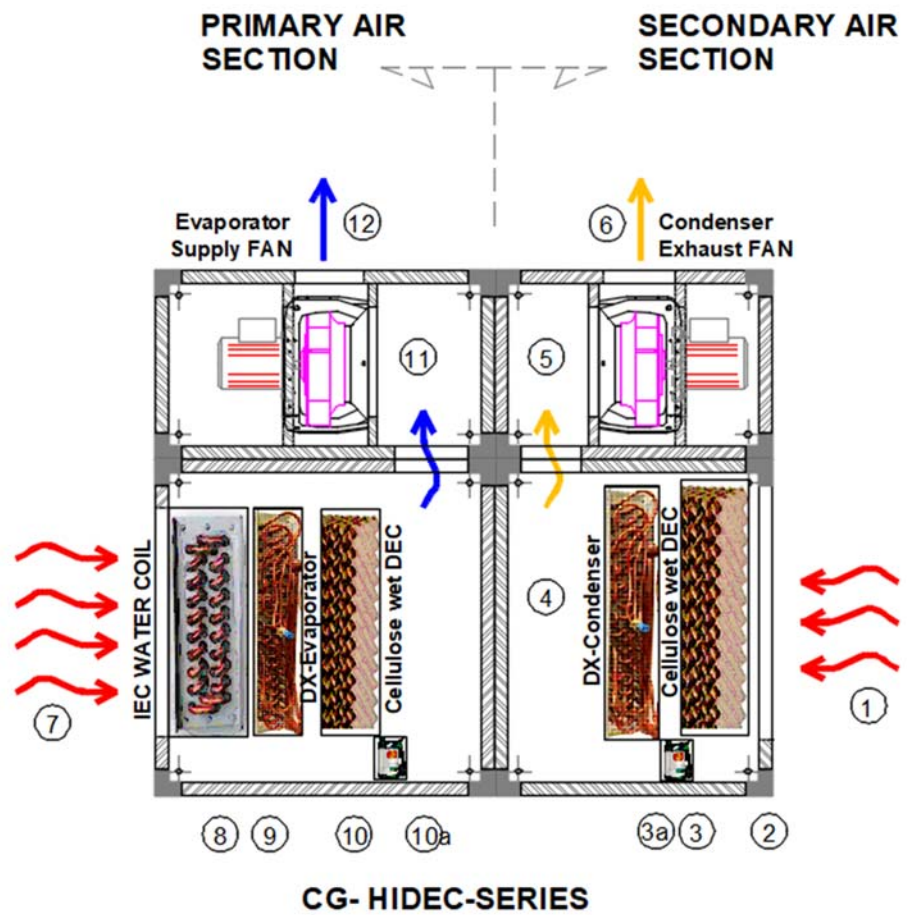



### CG-HIDEC series Working Principles

The unit designed to provide 100% full fresh air conditioning through stand-alone unit, while recovering the room return air prior exhausting to the outside as an optional.

the cooling process consist of three stages of cooling.

**First stage " Indirect evaporative cooling " :** The supply air fan blower drawn the 100% intake fresh air filtered through G4 filter and then entering to the IEC water cooling coil , the pre-cooled air that leaving the IEC coil it is sensible cooling process (no dehumidification occur), it is constant dew point process where no moisture add in the precooled air, IEC water coil deliver the cold water from the evaporative cooling pads located in secondary air section through the recirculating pump.

**Second stage "Cooling and Dehumidification”:** The pre-cooled air delivered to the DX cooling coil, as post cooling to achieve the room set temperature, the design of the DX cooling coil secures the accepted dew point temperature as  $60^{\circ} F$  ( $15.5^{\circ} C$ ) according to 2019, ASHRAE STD-62.1 Standard for accepted IAQ.

Two independent refrigerant circuits include two identical size of compressors as optimum part load operation and secure 50 % redundancy in case of any compressor failure.

The refrigerant condenses in the adiabatic evaporative cooling condenser located at the secondary air section.

**The Third stage " Adiabatic evaporative cooling”:** That provide post air cooling with adding moisture content to the air in case of dryness air hours.

*Noting: the primary air passing within enclosed air stream path, which is separate to the secondary air path, accordingly there is no risk of air containment's or mixing.*

### Different Cooling modes:

The are three different cooling modes manually or automatically adjusting according to the project requirements and operation scenarios.

- **Air Conditioning (Summer Mode):** Both of First Stage and second stage cooling process are activated to achieve the room preset temperature via the room thermostat and to at least guarantee the supply air leaving dew point temperature is no more than  $15.5^{\circ} C$ .
- **Free Cooling Mode:** In the HOT DRY AMBIENT HOURS, Only First Stage and third stage are activated as they could accommodate the cooling and humidification required for air tempering to reach to the accepted leaving conditions, this mode provide most efficient cooling performance.
- **Ventilation (Economizer Mode):** In the moderate ambient and where the outside air enthalpy is less than indoor or preset supply air leaving conditions, that ensure the indoor comfort satisfaction, only supply, and extract air fans shall activate.

The operator could select one of the specified modes through the room thermostat, or automatically operating the unit through pre-programming the control DDC module.

Summer Mode: IEC + DX Colling process at humid ambient DB: 40° C, WB:25° C, DP = 19° C

**CG-HIDEC**  
**STANDARD 100%**  
**FULL FRESH AIR**  
**CONDITIONING**  
**APPLICATION**  
*Summer Mode*  
*Humid ambient Hours*

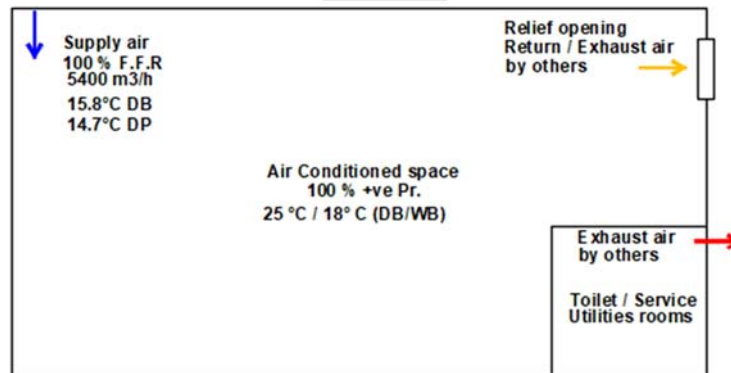
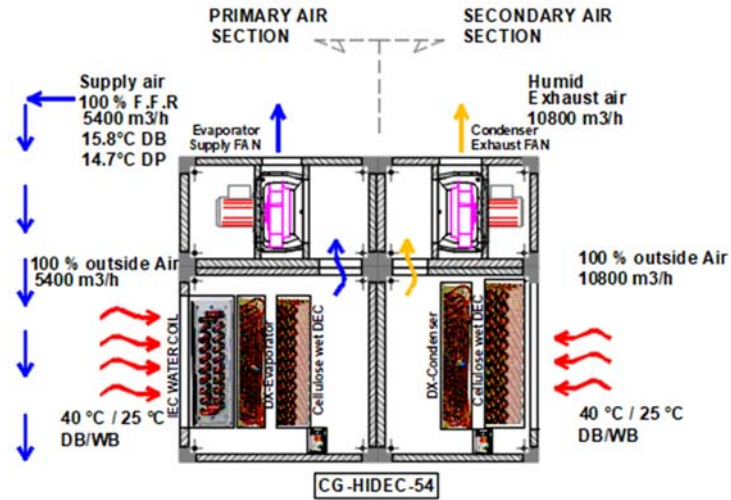

**Standard Air Conditioning**

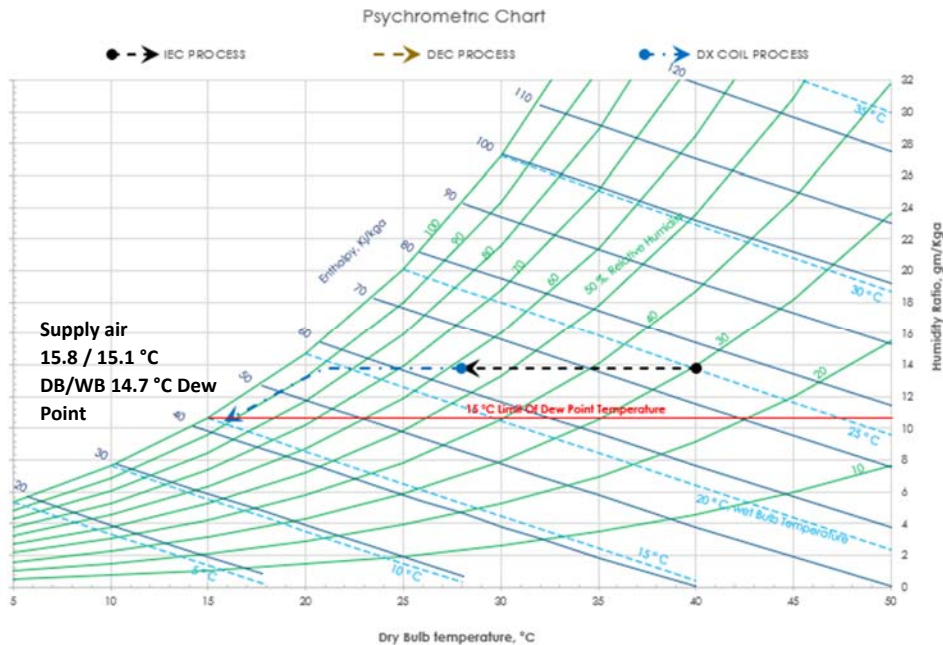

Free Cooling Mode: IDEC Colling process at dry ambient DB: 40° C, WB:20° C, DP = 6.5° C

**CG-HIDEC**  
**STANDARD 100%**  
**FULL FRESH AIR**  
**CONDITIONING**  
**APPLICATION**  
*Free Cooling Mode*  
*Dry ambient hours*

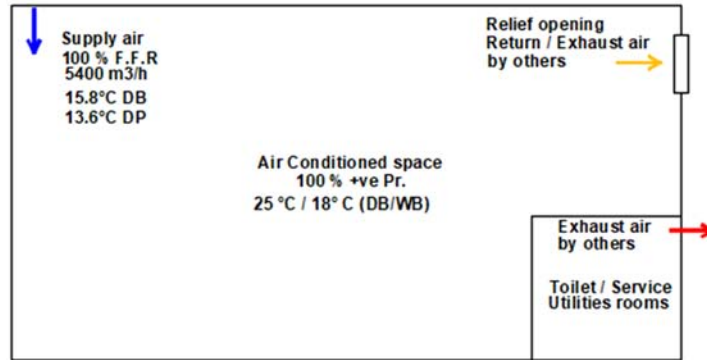
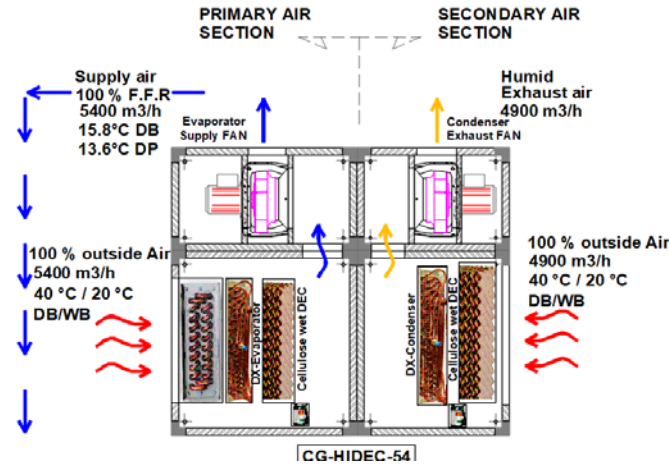

**HIDEC - Free Cooling Mode**

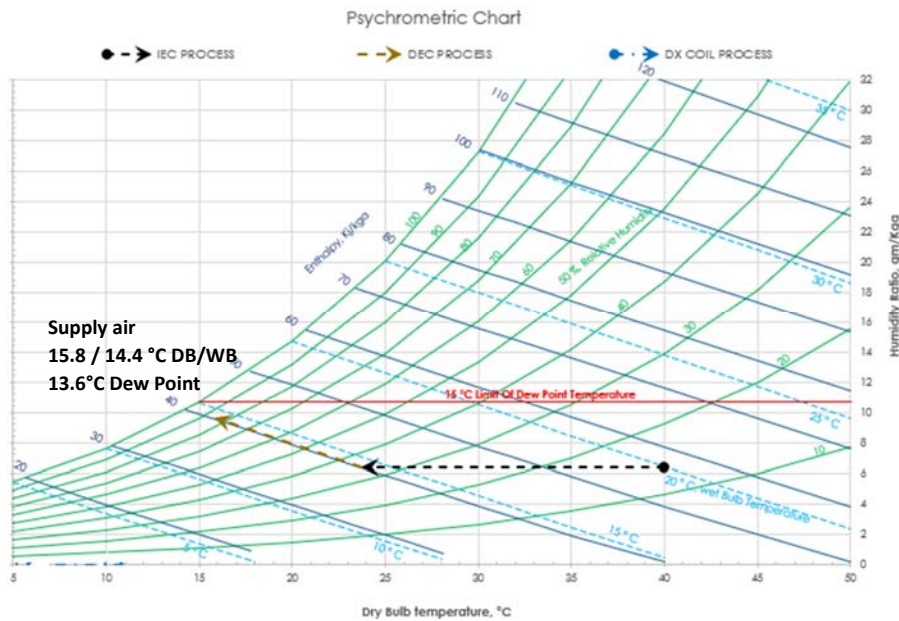

Energy Recovery: Return / Exhaust Air Recovery with accepted room pressurization level

### CG-HIDEC-ERV 100% FULL FRESH AIR CONDITIONING APPLICATION

#### Energy Recovery

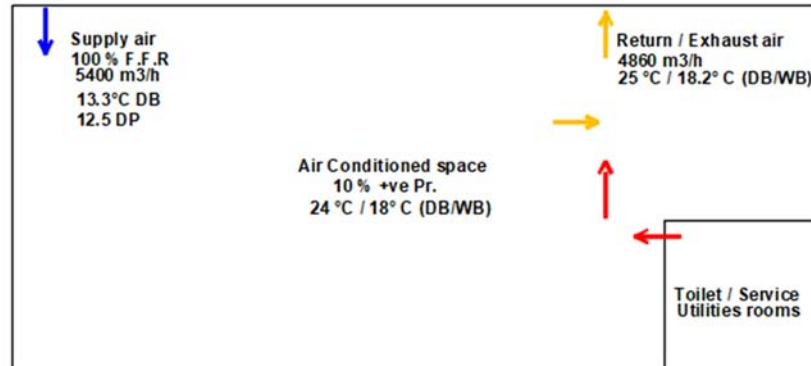
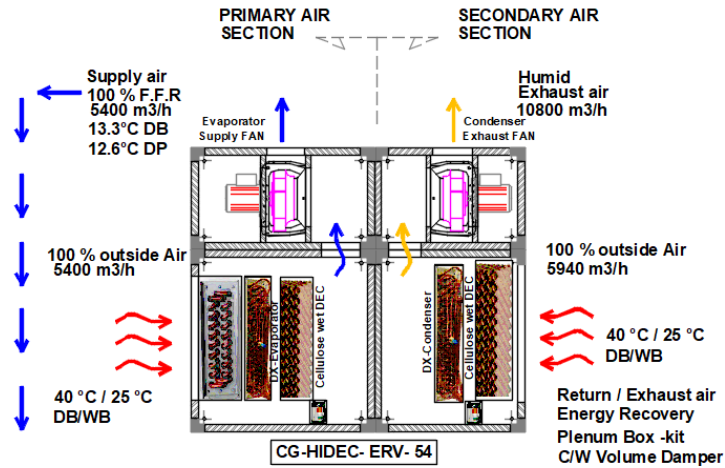

#### Energy Recovery Application

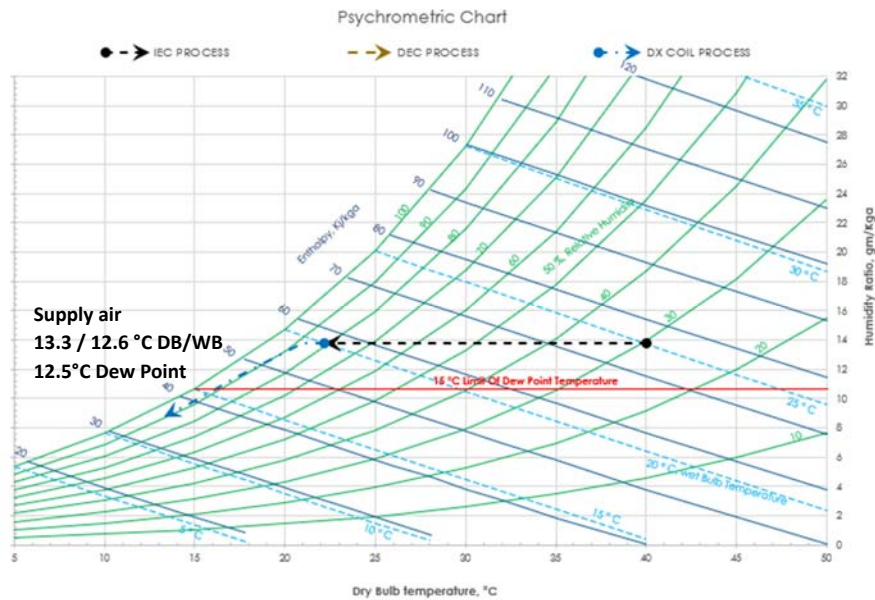

### Unit Constructions

#### Panel Construction

Aluminum Profile - Anodized - Rockwall insulated sandwich panels for primary air-cooling section. While single skin aluminum

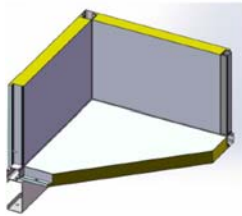

#### Drain Pans

Stainless Steel Drain pan with bottom pan drain hole sloped to side connection.



#### Base Frame

Epoxy Coated Heavy Duty black steel.



#### Profile Corners

Re-inforced Plastic / Nylon corners for aluminum



#### Door Lock

Door Lock in Nylon

#### Plug Fans

Primary / Secondary Supply air fans, High Efficiency non overloading high pressure backward Curved Centrifugal Plug Fan, Footed mounting, or Wall hanging, direct derive type, statically and dynamically balanced, Aluminum impeller complete with epoxy coated pedestal frame mounting in vibration isolators.



VFD, Variable frequency derive inverter to adjust the air flow against the actual fan static pressure, 0 to 10 v modulating speed control for part load power saving.

#### IEC Motors

premium efficiency - Aluminum Casing - anti corrosive coating squirrel cage induction motor, three phase standard IEC motor, insulation class - F, Efficiency class IE3, Ingress protection IP 54, continuous operation class S1



#### Scroll Compressor

*High Efficiency and cooling performance scroll compressor, dual or multi compressors per each unit.*

*R407C - new CFC - friendly refrigerant, low level of GWP, low power consumption , lower carbon emission.*



#### Acoustical Lining

acoustical absorption lining, around compressor partition

- Density: 25 ÷ 30 kg/m<sup>3</sup>
- Color: dark grey
- *Regular cellular structure*

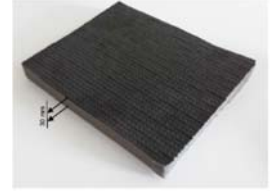

#### Air Intake Filter

Aluminum filters for large dust particles with aluminum frame and filter media in multi-layered flat aluminum wire, Washable. Class: G2, Mounting: on slide rails or in frames, drawn to sides *through access panel*.

*Optional Synthetic filter G4 grade.*

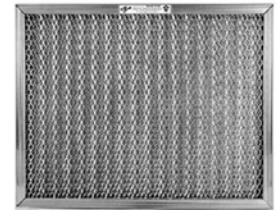

#### Water and or Dx- Coils

Copper tubes Aluminum fins air to water or refrigerant heat exchanger coil, either water , evaporator or condenser.

The collectors of the coils are equipped with nipples for vent and drain.

The water and direct expansion coils have holes at the lower cover for the drainage of the condensate in the drain pan.

*The coils, in standard execution, are subjected to a pneumatic test at a pressure of 30 Bar, by injection of dry air and water immersion.*



#### Coils Enclosures

The coils are housed in specific sections and individually mounted on "L" rails. For easy disassembly, at each coil corresponds a dedicated front panel.

Seals of passage of the collectors EPDM exclusive design to ensure a perfect air tightness and look perfectly smooth and easily washable inside the panel. The coil can be removed easily, leaving in place the gaskets.



### Direct Evaporative Cooling Pads

Cellulose paper with thickness 200 mm, flute 7 for primary air IEC water coil circuit, while thickness 150mm, flute 5 spacing for primary air post cooling

The wet adiabatic evaporative cooling with recirculated water is equipped with circulating pump and by-pass valve for regulating the flow of water to the wet deck. The tank has a lower sump in which are housed the pump with.

stainless steel mesh filter, the make-up floating valve, the overflow with the drain plug. The lower sump in the water basin allows to reduce the amount of water present in the basin and, resulting almost emptied at each switch over of the pump, ensures the necessary bleed -off (to reduce the concentration of salts in the water and ensure a periodical replacement of the same).

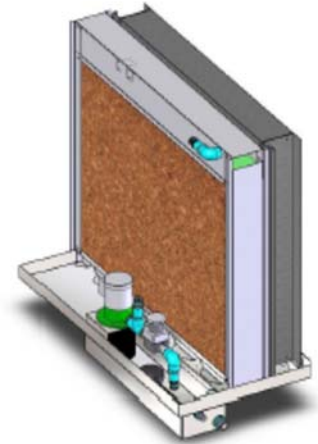

### Water Circulating Pump

submersible type - stainless steel water circulating pump European certified, heavy-duty operation for long lifetime and minimum trouble shooting.



### Electrical Components

Miniature Circuit Breakers, Motor Circuits Breakers, Contactors, relays, overload, .....



### Room Thermostat

Wall bus Room Sensors and Displays, both units include a temperature sensor and can output the temperature in either °C or °F. There are versions which include humidity and/or CO2 sensors. Versions with temperature and humidity sensors will also calculate dew point and make it available to the controller.



### DDC module controller

The module is terminal unit controllers for use with BACnet over MS/TP. They have from 9 to 18 I/O channels, and the ability to download a fixed strategy from a library.



ASHRAE **BACnet**<sup>™</sup>  
BACnet<sup>™</sup> is a trademark of ASHRAE.

### Physical DATA

Model Serial Number	CG-HIDEc-54	CG-HIDEc-81	CG-HIDEc-108	CG-HIDEc-162	CG-HIDEc-216
Nominal air Flow (m3/h)	5,400	8,100	10,800	16,200	21,600
(CFM)	<b>3,000</b>	<b>4,500</b>	<b>6,000</b>	<b>9,500</b>	<b>12,000</b>
Max. Cooling - KW (RT) *	72 ( <b>20</b> )	108 (30)	140 ( <b>40</b> )	210 ( <b>60</b> )	280 ( <b>80</b> )
STD. Cooling (KW) / (RT) **	45 ( <b>12</b> )	68 ( <b>19</b> )	84 ( <b>24</b> )	126 (36)	168 ( <b>48</b> )
Power Cons. Kw (Max/STD)***	15 / 8.3	23 / 13.0	30 / 16.6	45 / 25	60 / 33
COP (Max/STD)	4.7 / 5.0				
EER (Max/STD) BTUH/W	16 / 17				
Refrigerant Circuits	2	2	2	4	4
Circuits arrange.	Interwind				
Expansion Valve	TXV - Thermal Expansion Valve				
<b>Compressor</b>					
Type	Scroll				
Capacity (HP)	6	9	12	9	12
Quantity	2	2	2	4	4
Capacity MBH	72	108	144	108	144
Refrigerant	R407C				
Oil	Polyester Ester				
RLA (amp)	9	15.5	19.9	15.5	19.9
LRA (amp)	74	111	118	111	118
Speed	2900				
Voltage	380/3/50				
<b>DX - Evaporator Coil</b>					
Type	CU/ALU fins				
No of rows	6				
Face Velocity (m/s)	2.5 - 3.0				
Frame Coating	Epoxy				
Refrigerant	R407C				
Air Pressure Drop (pa)	160				
<b>DX - Condenser Coil</b>					
Type	CU/ALU fins				
No of rows	6				
Face Velocity (m/s)	3				
Fin Coating	Golden paint				
Refrigerant	R407C				
Air Pressure Drop (pa)	140				
<b>IEC water Cooling Coil</b>					
Type	CU/ALU fins				
No of rows	10				

### Physical data continued

Face Velocity (m/s)	2.5 to 2.75				
Frame Coating	Epoxy				
Air Pressure Drop (pa)	160				
<b>IEC-Recirculating pump</b>					
Type	Submersible				
Material	Stainless Steel				
Quantity	1	1	1	2	2
Capacity (Kw)	0.55	0.75	1.1	0.75	1.1
Voltage	380/3/50				
<b>IEC - Evaporative Cooling - Pads</b>					
Type	Flute - 7				
Material	Cellulose paper				
Face Velocity (m/s)	0.55	0.75	1.1	1.5	2.2
Thickness (mm)	200				
Air Pressure Drop (pa)	120				
Efficiency (%)	80				
<b>DEC - Evaporative Cooling - Pads</b>					
Type	Flute - 5				
Material	Cellulose paper				
Face Velocity (m/s)	2.5 to 3.0				
Area (m2)	0.55	0.75	1.1	1.5	2.2
Thickness (mm)	150				
Air Pressure Drop (pa)	90				
Efficiency (%)	85				
<b>Primary - Supply Air Fan</b>					
Type	Plug Fan				
Nominal Air Flow (m3/h)	5,400	8,100	10,800	8,100	10,800
Quantity	1	1	1	2	2
Size (mm)	450	500	560	500	500
Material	Aluminum				
Frame Coating	Epoxy				
Derive	Direct				
Speed	VFD				
Motor	IEC				
Power (Kw)	1.1	1.5	3.0	1.5	2.2
Efficiency Class	IE3				
Insulation Class	F				
Ingress Protection	IP54				
<b>Secondary - Exhaust Air Fan</b>					

### Physical data continued

Type	Plug Fan	Plug Fan	Plug Fan	Plug Fan	Plug Fan
Nominal Air Flow (m3/h)	10,800	16,000	21,000	16,000	21,000
Quantity	1	1	2	2	2
Size (mm)	500	560	560	560	560
Material	Aluminum				
Frame Coating	Epoxy				
Derive	Direct				
Speed	VFD				
Motor	IEC				
Power (Kw) / Each	2.2	3	2.2	3	5
Efficiency Class	IE3				
Insulation Class	F				
Ingress Protection	IP54				
<b>Filters</b>					
Type	Pre-filter	Pre-filter	Pre-filter	Pre-filter	Pre-filter
Material	Aluminum-Washable type				
Face Velocity (m/s)	2.5 to 3.0				
Thickness (mm)	25	25	50	50	50
Air Pressure Drop (pa)	50	50	65	65	65
EU - Efficiency Grade	G4				
<b>Electrical / Control</b>					
Electrical Panel	Panel Components by Schnieder				
Control Thermostat	Room Thermostat - Three position modes				
Operation Modes	1 - Air Conditioning, 2- Free Cooling , 3- Ventilation Mode				
Control Module	DDC - Controller by Trend / Honeywell				
<b>Dimensions / Weights</b>					
Dimensions L X W X H (m)	2.4 x 1.4 x 2.1	2.4 x 2.0 x 2.2	2.4 x 2.6 x 2.2	2.6 x 3.6 x 2.2	2.6 x 4.8 x 2.2
Weights (kg) – Estimated	460	620	780	1050	1460

- Max. Cooling – kw (RT) \* : Based on the maximum output cooling capacity at high ambient.

- STD. Cooling kw (RT) \*\* : Based on ASHRAE Standard 143 as 38 °C DB ambient temperature and 21 °C Wet Bulb Temperature

- Power Cons. Kw (Max/STD) \*\*\* : **Max.** including two compressors, while **STD** :Only one compressor circuit in duty.

- Unit could stable in duty working as much as outdoor temperature of 50 °C

### Cooling Performance

The unit Cooling Performance table charts based on performance envelope that guarantee the supply air leaving dew point temperature is not more 15.5 °C, it is not meaning that the unit shall not work above these outdoor conditions limit but it means that the supply air flow shall adjusted down step to secure the cooling achievement of the specified dew point temperature, ask for computer selection via Clima-pro ver.01 to get the precises selection at different conditions.

The cooling performance tables show the cooling capacity, power consumption, coefficient of performance and the makeup water for the unit model **CG-HIDEC-54** and **CG-HIDEC- 54 - ERV** models with nominal air flow of 5400 m3/h. the performance envelope of the ERV have much more boundary of ambient conditions and provide better cooling performance around 7 % more than the standard unit.

for the cooling performance of the other larger unit capacity, please refer to the capacity correction table.

*Noting that, The nominal unit rating based on 38 °C DB and 21 °C WB ambient temperatures in accordance to 2015- ASHRAE STD-143, Method of test and measurements the Indirect Evaporative cooling units.*

**CG-HIDEC-54 : 5,400 m3/h Supply air flow - No Exhaust / Return air - 100 % space positive pressure**

Ambient WB °C	Cooling Capacity (kw)																
	Dry Bulb Temperature - DB °C																
	18	20	22	24	26	28	30	32	34	36	38	40	42	44	46	48	50
7		19.7															
8		18.6	23.6														
9		17.3	22.4	27.5	32.5												
10		15.7	21.2	26.3	31.3	36.4											
11		14.2	19.6	25.0	30.1	35.1	40.2										
12		12.6	17.9	23.3	28.8	33.9	38.9	43.9									
13		11.0	16.3	21.6	27.0	32.5	37.6	42.6	47.7								
14		9.4	14.7	20.0	25.3	30.7	36.1	41.2	46.3	50.9							
15		21.1	25.3	18.3	23.6	28.9	34.3	39.5	44.2	48.8	53.3	57.9					
16		21.0	25.3	29.4	21.8	27.1	32.0	36.8	41.5	46.4	51.1	55.7	60.3				
17		21.0	25.3	29.5	33.4	24.7	29.3	34.0	38.8	43.6	48.5	53.2	58.0	62.6			
18		21.0	25.3	28.8	31.7	34.7	37.8	31.5	36.2	40.8	45.6	50.4	55.2	60.1	64.8	69.4	
19		21.0	23.9	27.0	30.1	33.2	36.3	39.1	33.5	38.2	42.9	47.6	52.3	57.1	61.9	66.7	71.6
20		40.3	43.2	46.2	28.5	31.4	34.5	37.5	40.5	43.5	40.2	44.8	49.5	54.3	59.0	63.7	68.5
21		36.4	41.6	44.3	47.3	50.3	32.9	35.9	38.7	41.7	44.7	47.6	46.9	51.4	56.1	60.8	65.6
22			39.7	42.6	45.7	48.6	51.2	54.0	56.8	40.1	43.1	45.9	48.9	48.8	53.4	58.0	62.6
23				43.7	46.6	49.5	52.3	55.1	57.7	60.6	44.4	47.4	50.4	53.2	55.2	59.8	
24					50.3	53.2	56.0	58.9	61.9	64.5	67.4	70.4	73.4	76.4	79.4	82.4	
25						57.1	60.0	62.9	65.8	68.7	71.2	73.9	76.6	79.3	82.0	84.7	
26							64.0	66.7	69.5	72.2	74.9	77.6	80.3	83.0	85.7	88.4	
27											72.3	75.0	77.7	80.4	83.1	85.8	
28																	
29																	
30																	
31																	
32																	

\* The performance envelope is limited to supply air flow 5400 m3/h and maximum leaving DP as 15.5 ° C, for different conditions please contact us for software selection.

  IDEC mode        HIEC mode



# Packaged Hybrid Indirect / Direct Evaporative Cooling Unit

## CG – HIDEC series

		Power Consumption (kw)																
Ambient		Dry Bulb Temperature - DB °C																
WB °C		18	20	22	24	26	28	30	32	34	36	38	40	42	44	46	48	50
7			1.6															
8			1.6	1.6														
9			1.6	1.6	1.6													
10			1.6	1.6	1.6	1.6												
11			1.6	1.6	1.6	1.6	1.6											
12			1.6	1.6	1.6	1.6	1.6	1.6										
13			1.6	1.6	1.6	1.6	1.6	1.6	1.6									
14			1.6	1.6	1.6	1.6	1.6	1.6	1.6	1.6								
15			7.4	7.5	1.6	1.6	1.6	1.6	1.6	1.6	1.6	1.6	1.6					
16			7.4	7.5	7.5	1.6	1.6	1.6	1.6	1.6	1.6	1.6	1.6	1.6				
17			7.4	7.5	7.5	7.5	1.6	1.6	1.6	1.6	1.6	1.6	1.6	1.6	1.6			
18			7.4	7.5	7.5	7.6	7.6	7.7	7.7	1.6	1.6	1.6	1.6	1.6	1.6	1.6	1.6	
19			7.4	7.5	7.6	7.6	7.7	7.7	7.8	1.6	1.6	1.6	1.6	1.6	1.6	1.6	1.6	1.6
20			11.5	11.6	11.7	7.6	7.7	7.8	7.9	8.0	8.1	1.6	1.6	1.6	1.6	1.6	1.6	1.6
21			11.5	11.6	11.7	11.9	12.0	7.8	7.9	8.0	8.1	8.2	8.3	1.6	1.6	1.6	1.6	1.6
22				11.7	11.8	11.9	12.1	12.3	12.5	12.7	8.2	8.3	8.4	8.5	1.6	1.6	1.6	1.6
23					12.0	12.2	12.4	12.6	12.8	13.0	13.2	13.3	8.5	8.6	8.6	6.7	1.6	1.6
24								12.7	13.0	13.2	13.3	13.5	13.7	13.8	13.9	8.8	8.9	7.1
25												13.5	13.7	13.8	14.0	14.2	14.5	14.8
26															14.2	14.4	14.7	15.0
27																		15.0
28																		
29																		
30																		
31																		
32																		

\* The performance envelope is limited to supply air flow 5400 m3/h and maximum leaving DP as 15.5 ° C, for different conditions please contact us for software selection.

		COP - "Coefficient Of Performance"																
Ambient		Dry Bulb Temperature - DB °C																
WB °C		18	20	22	24	26	28	30	32	34	36	38	40	42	44	46	48	50
7			11.6															
8			10.8	14.0														
9			9.8	13.2	16.4	19.6												
10			8.8	12.2	15.6	18.8	22.0											
11			7.9	11.2	14.6	18.0	21.2	24.3										
12			6.9	10.2	13.5	16.9	20.3	23.5	26.6									
13			5.9	9.2	12.5	15.8	19.2	22.6	25.8	28.9								
14			2.8	3.4	11.4	14.7	18.1	21.4	24.7	27.6	30.5							
15			2.8	3.4	3.9	13.6	16.9	20.0	23.0	25.9	29.0	31.9	34.8					
16			2.8	3.4	3.9	4.4	15.4	18.3	21.3	24.3	27.3	30.3	33.2	36.2				
17			2.8	3.4	3.9	4.4	15.4	18.3	21.3	24.3	27.3	30.3	33.2	36.2	39.1			
18			2.8	3.4	3.8	4.2	4.5	4.9	19.7	22.6	25.5	28.5	31.5	34.5	37.5	40.5	43.4	
19			2.8	3.2	3.6	4.0	4.3	4.7	5.0	20.9	23.9	26.8	29.8	32.7	35.7	38.7	41.7	44.7
20			3.5	3.7	4.0	3.7	4.1	4.4	4.8	5.1	5.4	25.1	28.0	31.0	33.9	36.9	39.8	42.8
21			3.2	3.6	3.8	4.0	4.2	4.2	4.5	4.8	5.1	5.4	5.7	29.3	32.1	35.1	38.0	41.0
22				3.4	3.6	3.8	4.0	4.2	4.3	4.5	4.9	5.2	5.5	5.8	30.5	33.4	36.3	39.1
23					3.6	3.8	4.0	4.1	4.3	4.4	4.6	5.2	5.5	5.8	5.8	7.9	34.5	37.4
24								3.9	4.1	4.3	4.4	4.6	4.6	4.7	4.8	5.9	6.1	8.2
25												4.2	4.4	4.5	4.7	4.8	4.9	5.0
26															4.5	4.6	4.7	4.8
27																		4.8
28																		
29																		
30																		
31																		
32																		

\* The performance envelope is limited to supply air flow 5400 m3/h and maximum leaving DP as 15.5 ° C, for different conditions please contact us for software selection.



# Packaged Hybrid Indirect / Direct Evaporative Cooling Unit

## CG – HIDEC series

Ambient WB °C	Make Up water (l/h)																
	Dry Bulb Temperature - DB °C																
	18	20	22	24	26	28	30	32	34	36	38	40	42	44	46	48	50
7	8.7																
8	8.1	37.7															
9	7.4	35.6	46.6														
10	6.8	33.5	44.5	57.6													
11	6.1	31.2	42.2	53.2	66.4												
12	5.4	29.0	39.9	50.9	61.9	75.1											
13	4.8	26.7	37.6	48.5	59.5	70.4	83.7										
14	4.1	24.5	35.3	46.2	57.1	68.0	78.9	92.3									
15	0.0	13.7	32.9	43.8	54.6	65.5	75.8	85.0	99.1								
16	0.0	13.7	27.5	41.4	52.2	61.7	70.9	79.8	89.0	103.1	112.3						
17	0.0	13.8	27.5	40.5	47.8	56.6	65.8	75.0	84.1	93.3	102.1	111.3	120.4				
18	0.0	13.8	25.5	35.1	45.3	55.5	61.1	70.2	79.0	88.1	97.2	106.3	115.4	124.2	133.3		
19	0.0	9.6	20.0	30.3	40.6	50.8	60.3	65.2	74.2	83.3	92.3	101.0	110.1	119.2	128.2	137.3	
20	0.0	4.8	15.2	25.5	35.1	45.4	55.6	65.8	75.9	85.2	94.2	103.1	112.3	121.6	130.9	140.2	149.5
21	0.0	0.0	9.6	20.0	30.3	40.6	50.8	60.4	70.5	80.7	90.8	100.9	111.0	121.1	131.2	141.3	151.4
22		0.0	4.8	15.2	25.5	35.1	45.4	55.6	65.8	76.0	86.1	96.2	106.3	116.4	126.5	136.6	146.7
23			0.0	9.6	20.0	30.3	40.6	50.9	60.4	70.6	80.8	90.9	101.0	111.1	121.2	131.3	141.4
24				4.8	15.2	25.5	35.1	45.4	55.7	65.9	76.1	86.2	96.3	106.4	116.5	126.6	136.7
25					9.6	20.0	30.3	40.6	50.9	61.0	71.1	81.2	91.3	101.4	111.5	121.6	131.7
26						15.2	25.5	35.1	45.4	55.7	65.9	76.0	86.1	96.2	106.3	116.4	126.5
27							20.0	30.3	40.6	50.9	61.0	71.1	81.2	91.3	101.4	111.5	121.6
28								30.3	40.6	50.9	61.0	71.1	81.2	91.3	101.4	111.5	121.6
29									40.6	50.9	61.0	71.1	81.2	91.3	101.4	111.5	121.6
30										50.9	61.0	71.1	81.2	91.3	101.4	111.5	121.6
31											61.0	71.1	81.2	91.3	101.4	111.5	121.6
32												71.1	81.2	91.3	101.4	111.5	121.6

\* The performance envelope is limited to supply air flow 5400 m3/h and maximum leaving DP as 15.5 ° C, for different conditions please contact us for software selection.

**CG-HIDEC-ERV-54** : 5,400 m3/h supply air flow including energy recovery with 90 % of Supply air "4,860 m3/h (25°C / 18 °C DB/WB) Exhaust / Return air"- 10 % space positive pressure

Ambient WB °C	Cooling Capacity (kw)																
	Dry Bulb Temperature - DB °C																
	18	20	22	24	26	28	30	32	34	36	38	40	42	44	46	48	50
7	19.7																
8	18.6	23.6															
9	17.3	22.4	27.2	31.7													
10	15.7	21.2	26.0	30.5	35.1												
11	14.2	19.6	24.7	29.3	33.8	38.4											
12	12.6	17.9	23.0	27.7	32.5	37.1	41.7										
13	11.0	16.3	21.3	26.0	30.9	35.8	40.4	45.0									
14	9.4	14.7	19.6	24.3	29.1	34.0	38.8	43.6	48.1								
15	21.1	25.3	18.0	22.6	27.4	32.2	37.0	41.8	46.6	51.2	55.8						
16	21.0	25.3	29.4	20.9	25.6	30.4	35.1	39.9	44.7	49.5	54.3	58.9					
17	21.0	25.3	29.5	32.6	23.9	28.6	33.3	38.1	42.7	47.5	52.4	57.3	61.9				
18	21.0	25.3	28.8	31.7	34.7	37.8	40.8	43.8	46.8	49.8	52.8	55.8	58.8	63.4	68.0	72.6	77.2
19	21.0	24.8	27.7	30.8	33.8	36.9	40.0	43.1	46.2	49.3	52.4	55.5	58.6	61.7	64.8	67.9	71.0
20	41.9	44.9	26.8	29.9	33.0	36.0	39.1	42.1	45.2	48.3	51.4	54.5	57.6	60.7	63.8	66.9	70.0
21	36.4	43.7	46.7	49.7	32.1	35.2	38.2	41.0	44.0	46.9	49.9	52.8	55.8	58.8	61.8	64.8	67.8
22		43.7	45.7	48.8	51.7	54.6	57.2	60.1	63.0	65.9	68.8	71.7	74.6	77.5	80.4	83.3	86.2
23			45.7	47.8	50.8	53.7	56.3	59.1	61.9	64.7	67.5	70.3	73.1	75.9	78.7	81.5	84.3
24				47.8	50.8	53.7	56.3	59.1	61.9	64.7	67.5	70.3	73.1	75.9	78.7	81.5	84.3
25					50.8	53.7	56.3	59.1	61.9	64.7	67.5	70.3	73.1	75.9	78.7	81.5	84.3
26						53.7	56.3	59.1	61.9	64.7	67.5	70.3	73.1	75.9	78.7	81.5	84.3
27							56.3	59.1	61.9	64.7	67.5	70.3	73.1	75.9	78.7	81.5	84.3
28								59.1	61.9	64.7	67.5	70.3	73.1	75.9	78.7	81.5	84.3
29									61.9	64.7	67.5	70.3	73.1	75.9	78.7	81.5	84.3
30										64.7	67.5	70.3	73.1	75.9	78.7	81.5	84.3
31											67.5	70.3	73.1	75.9	78.7	81.5	84.3
32												70.3	73.1	75.9	78.7	81.5	84.3

\* The performance envelope is limited to supply air flow 5400 m3/h and maximum leaving DP as 15.5 ° C, for different conditions please contact us for software selection.



# Packaged Hybrid Indirect / Direct Evaporative Cooling Unit

## CG – HIDEC series

		Power Consumption (kw)															
Ambient		Dry Bulb Temperature - DB °C															
WB °C	18	20	22	24	26	28	30	32	34	36	38	40	42	44	46	48	50
7		1.6															
8		1.6	1.6														
9		1.6	1.6	1.6	1.6												
10		1.6	1.6	1.6	1.6	1.6											
11		1.6	1.6	1.6	1.6	1.6	1.6										
12		1.6	1.6	1.6	1.6	1.6	1.6	1.6									
13		1.6	1.6	1.6	1.6	1.6	1.6	1.6	1.6								
14		1.6	1.6	1.6	1.6	1.6	1.6	1.6	1.6	1.6							
15		7.4	7.5	1.6	1.6	1.6	1.6	1.6	1.6	1.6	1.6	1.6					
16		7.4	7.5	7.5	1.6	1.6	1.6	1.6	1.6	1.6	1.6	1.6	1.6				
17		7.4	7.5	7.5	7.6	1.6	1.6	1.6	1.6	1.6	1.6	1.6	1.6	1.6			
18		7.4	7.5	7.5	7.6	7.6	7.7	1.6	1.6	1.6	1.6	1.6	1.6	1.6	1.6	1.6	
19		7.4	7.5	7.5	7.6	7.7	7.7	7.8	1.6	1.6	1.6	1.6	1.6	1.6	1.6	1.6	
20		11.4	11.5	7.6	7.6	7.7	7.7	7.8	7.9	8.0	1.6	1.6	1.6	1.6	1.6	1.6	1.6
21		11.5	11.6	11.7	11.8	7.7	7.7	7.8	8.0	8.1	8.2	8.3	1.6	1.6	1.6	1.6	1.6
22			11.7	11.7	11.8	11.9	12.0	12.3	8.0	8.1	8.2	8.3	8.4	1.6	1.6	1.6	1.6
23				11.8	11.8	12.0	12.1	12.3	12.5	12.8	8.2	8.3	8.4	8.5	8.6	1.6	1.6
24							12.2	12.4	12.6	12.8	13.0	13.2	13.4	8.6	8.6	8.7	8.8
25									12.6	12.8	13.0	13.2	13.4	13.6	13.8	8.7	8.8
26									12.6	12.7	12.8	12.9	13.1	13.3	13.5	13.7	8.7
27												13.1	13.2	13.2	13.5	13.7	13.9
28															13.5	13.7	13.9
29																	
30																	
31																	
32																	

\* The performance envelope is limited to supply air flow 5400 m3/h and maximum leaving DP as 15.5 ° C, for different conditions please contact us for software selection.

		COP - "Coefficient Of Performance"															
Ambient		Dry Bulb Temperature - DB °C															
WB °C	18	20	22	24	26	28	30	32	34	36	38	40	42	44	46	48	50
7		12.3															
8		11.6	14.7														
9		10.8	14.0	17.0	19.8												
10		9.8	13.2	16.3	19.1	21.9											
11		8.8	12.2	15.4	18.3	21.1	24.0										
12		7.9	11.2	14.4	17.3	20.3	23.2	26.1									
13		6.9	10.2	13.3	16.3	19.3	22.3	25.2	28.1								
14		5.9	9.2	12.3	15.2	18.2	21.2	24.3	27.2	30.0							
15		2.8	3.4	11.2	14.1	17.1	20.1	23.1	26.1	29.1	32.0	34.9					
16		2.8	3.4	3.9	13.1	16.0	19.0	22.0	25.0	27.9	30.9	33.9	36.8				
17		2.8	3.4	3.9	4.3	14.9	17.9	20.8	23.8	26.7	29.7	32.7	35.8	38.7			
18		2.8	3.4	3.8	4.2	4.5	4.9	19.7	22.6	25.5	28.5	31.5	34.5	37.5	40.5	43.4	
19		2.8	3.3	3.7	4.1	4.4	4.8	5.1	21.5	24.3	27.3	30.2	33.2	36.2	39.2	42.2	
20		3.7	3.9	3.5	3.9	4.3	4.7	5.0	5.3	5.6	26.1	29.0	31.9	34.9	37.8	40.8	43.8
21		3.2	3.8	4.0	4.2	4.2	4.5	4.9	5.2	5.5	5.8	6.0	30.7	33.6	36.5	39.5	42.4
22			3.8	3.9	4.1	4.3	4.5	4.7	5.0	5.3	5.6	5.9	6.2	32.3	35.2	38.1	41.1
23				3.9	4.0	4.3	4.4	4.6	4.7	4.9	5.5	5.8	6.1	6.3	6.6	36.8	39.7
24							4.3	4.5	4.6	4.8	4.9	5.0	5.2	6.2	6.5	6.8	7.1
25									4.6	4.8	4.9	5.0	5.2	5.3	5.4	6.8	7.1
26									5.3	5.3	5.4	5.6	5.7	5.9	6.0	6.1	7.8
27												5.5	5.6	5.9	6.0	6.1	6.2
28															5.9	6.0	6.2
29																	
30																	
31																	
32																	

\* The performance envelope is limited to supply air flow 5400 m3/h and maximum leaving DP as 15.5 ° C, for different conditions please contact us for software selection.



# Packaged Hybrid Indirect / Direct Evaporative Cooling Unit

## CG – HIDEc series

Ambient WB °C	Make Up water (l/h)																
	Dry Bulb Temperature - DB °C																
	18	20	22	24	26	28	30	32	34	36	38	40	42	44	46	48	50
7		43.1															
8		39.5	42.2														
9		36.5	39.0	40.7	41.6												
10		34.3	36.3	38.0	38.9	39.5											
11		32.1	34.6	35.8	36.5	37.2	37.4										
12		29.9	32.9	34.6	35.1	35.2	35.5	35.4									
13		27.7	31.2	33.3	34.2	34.6	34.2	34.0	33.5								
14		25.4	29.5	32.1	33.4	34.1	34.2	33.6	32.7	31.7							
15		11.7	20.1	31.0	32.6	33.8	34.3	34.1	33.2	31.6	30.2	28.6					
16		11.7	20.5	28.7	31.9	33.6	34.5	34.7	34.3	33.0	31.2	29.1	27.1				
17		11.7	20.8	29.4	34.1	33.4	34.8	35.5	35.5	34.6	33.3	31.2	28.6	26.0			
18		11.8	21.2	28.0	32.4	37.1	41.3	36.4	36.9	36.5	35.6	34.0	31.7	28.8	25.2	22.0	
19		11.7	20.0	25.1	30.5	35.6	40.3	44.5	38.4	38.5	38.1	36.9	35.2	32.7	29.5	25.7	
20		11.0	17.3	22.6	28.4	33.9	39.0	43.7	47.2	51.0	40.8	40.2	38.9	36.9	34.1	30.9	21.6
21		0.0	13.8	20.1	26.2	31.9	37.4	42.5	46.6	50.9	54.7	58.0	42.9	41.4	39.1	36.3	26.9
22			9.9	17.4	23.7	29.8	35.6	40.4	45.6	50.4	54.8	58.8	61.5	46.4	44.5	42.3	32.9
23				13.6	21.2	27.6	33.7	38.8	44.4	49.6	54.6	59.1	62.5	66.1	69.1	48.6	39.3
24							31.6	37.0	42.9	48.6	54.0	59.0	62.9	67.2	71.0	74.2	46.2
25									60.4	67.5	73.3	79.4	84.3	88.9	92.3	96.0	76.9
26									60.1	66.4	72.3	79.5	86.1	91.2	95.9	99.6	99.2
27												79.0	85.7	96.1	98.5	102.7	103.5
28															99.3	104.7	107.3
29																	
30																	
31																	
32																	

\* The performance envelope is limited to supply air flow 5400 m3/h and maximum leaving DP as 15.5° C, for different conditions please contact us for software selection.

### Quick Selection Guidelines

	CG-HIDEc-54	CG-HIDEc-81	CG-HIDEc-108	CG-HIDEc-162	CG-HIDEc-216
STD Air Flow	5,400	8,100	10,800	16,200	21,600
Correction Factor	1.0	1.5	2.0	3.0	4.0
Air Flow Capacity	5,400	8,100	10,800	16,200	21,600

A) Identify the Ambient Conditions

Let Us Say the design ambient is **40 / 25 °C (DB / WB)**

B) Go to the **CG-HIDEc - 54** charts and take the cooling capacity, Power Consumption, COP and Make Up water.

C) Multiply the correction factor to get the relevant values in different models as described below

from CG-HIDEc - 54 - Cooling capacity Chart

Cooling Capacity (KW)	<b>60</b>	90	120	180	240
(RT)	<b>17</b>	<b>26</b>	<b>34</b>	<b>51</b>	<b>69</b>

from CG-HIDEc - 54 - Power Consumption Chart

Power Consumption (KW)	<b>13.7</b>	20.55	27.4	41.1	54.8
------------------------	-------------	-------	------	------	------

from CG-HIDEc - 54 - COP Chart

COP (KW/KW)	<b>4.4</b>	4.4	4.4	4.4	4.4
-------------	------------	-----	-----	-----	-----

from CG-HIDEc - 54 - Make Up Water Chart

Make Up Water (L/H)	<b>71</b>	106	141	212	283
---------------------	-----------	-----	-----	-----	-----

**Note :** 1- Make up water reflect the water evaporation excluding the blow down, bleeding and others.  
2- Clima-pro ver.01 provides precise computer selection with all the necessary information.

### Selection Software:

Clima-pro ver.01 software, provide flexibility for the unit selection either standard or energy recovery, the weather data extracted from 2019-ASHRAE-Climate, the user could write different outdoor design conditions through user defined option, as well as supply air flow and the return air conditions, and required room pressurization, the software provide all the air properties as well as process plotting in Psychrometric chart and cooling performance for each cooling stage. annual analysis also available in according to 2015-ASHRAE - IWECC "International Weather for Energy Calculations.

**IDEC-Hybrid - 5100 CMH**

**Supply Air @ 15.0 C Dew Point**

2019-Ashrae Climates | Ambient - User Defined

Select City: CAIRO | 0.4% DB / MCWB: 38.8 | 0.4% WB / MCDB: 21 | DB temp C: 25.4 | WB Temp C: 31.6 | DB temp C: 40 | WB Temp C: 25

Extract Ashrae Data

Supply Air Flow (m3/h): 5400 | Room Pressurization: 0 % | Exhaust Air Conditions: DB temp C: 27 | WB Temp C: 19

Exhaust Air Flow (m3/h): 5400

Daily Working Hours: Starting Hour: 8 | Ending Hour: 24 | Working Hours: 16

Calculate

Cooling Capacity	IEC coil	DX - Coil	Wet DEC pads	Over All Cooling
Sensible :	27.0	19.3	0.0	46.3 13.2 Kw RT
Total :	26.9	38.4		65.3 18.7 Kw RT

Power Consumption	Performance	Water Consumption
Supply Fan	COP	4.9
Exhaust Fan	BTUH/W	17
Compressors	Kw/RT	0.71
IEC pump	IEC - Eff.	97 %
DEC pump	IEC - Eff.	%
		<b>13.32 Kw</b>

**2019 Ashrae Climates**

City: CAIRO | Summer Cooling: 0.4 % DB/MCWB: 38.8 | 21.0 | Evaporation: 0.4 % WB/MCDB: 25.4 | 31.6

Supply Air Flow: 5400 m3/h | Exhaust Air Flow: 5400 m3/h | Room Pressurization: 0 %

**User Defined Ambient Air**

DB: 40.0 | WB: 25.0

**Room Exhaust Exh. Or Return air**

DB: 27.0 | WB: 19.0

**Primary Air Section**

- 7 Outside Air
- 8 IEC Water coil
- 9 DX Evap Coil
- 10 DEC Wet pads
- 10a DEC Wet pads pump
- 11 Supply Air Fan
- 12 Supply Air

**Primary Air Section - Process Analysis**

	10	9	8	7	
Flow	5,400			5,400	m3/h
DB Temp	14.7	14.7	25.4	40.0	°C
WB Temp	14.0	14.0	21.0	25.0	°C
Humidity Ratio	92.8	92.8	67.4	29.7	%
Enthalpy	39.3	39.3	60.7	76	kJ/kgda
Wet Bulb Temp	9.7	9.7	13.8	13.7	g/kgda
Wet Bulb Temp	13.6	13.6	19.0	19.0	°C
Wet Bulb Temp	OFF	ON	ON		

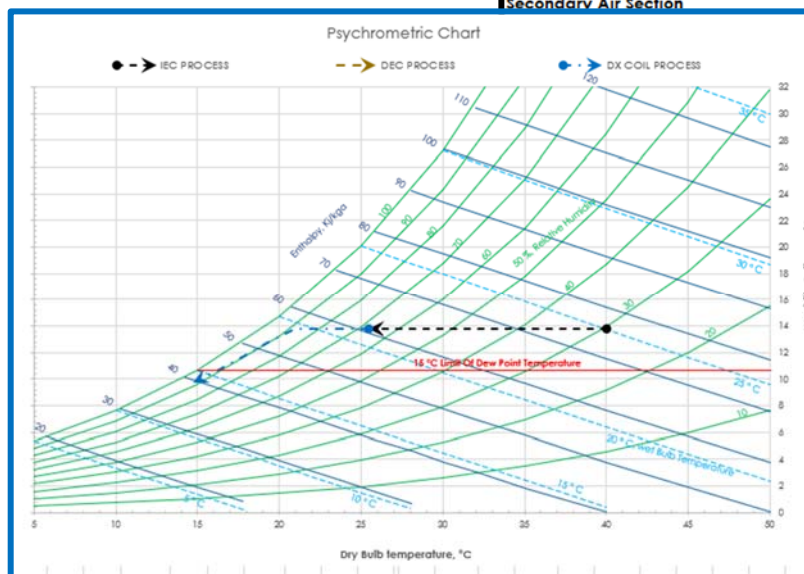

### Electrical wiring and Control

#### A) MCC – Motor Control Center

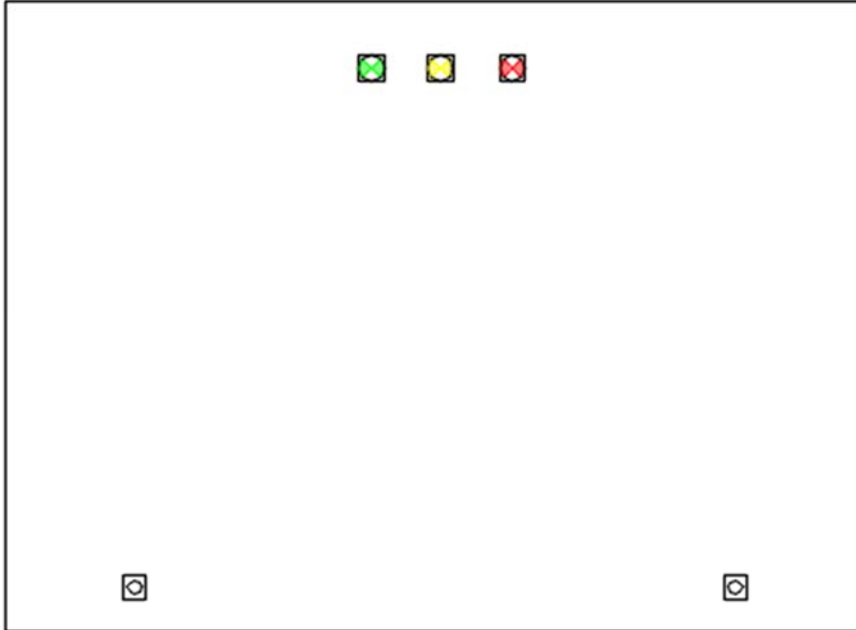

Figure 01

List of materials	
REF.	Serving
Q40	Main Incoming Feeder
F41	
F42	
F43	
UVR	
Q51	COND. FAN
VSD-01	EVAP. FAN
Q52	
VSD-02	COMP.-01
Q53	
K53	
FK53	COMP.-02
Q54	
K54	
FK54	IEC PUMP
Q55	
K55	
FK55	DEC PUMP
Q56	
K56	
FK56	PUMP
Q57	LCP FEEDER
Q58	INDICATIONS
H41,42,43	

Figure 03

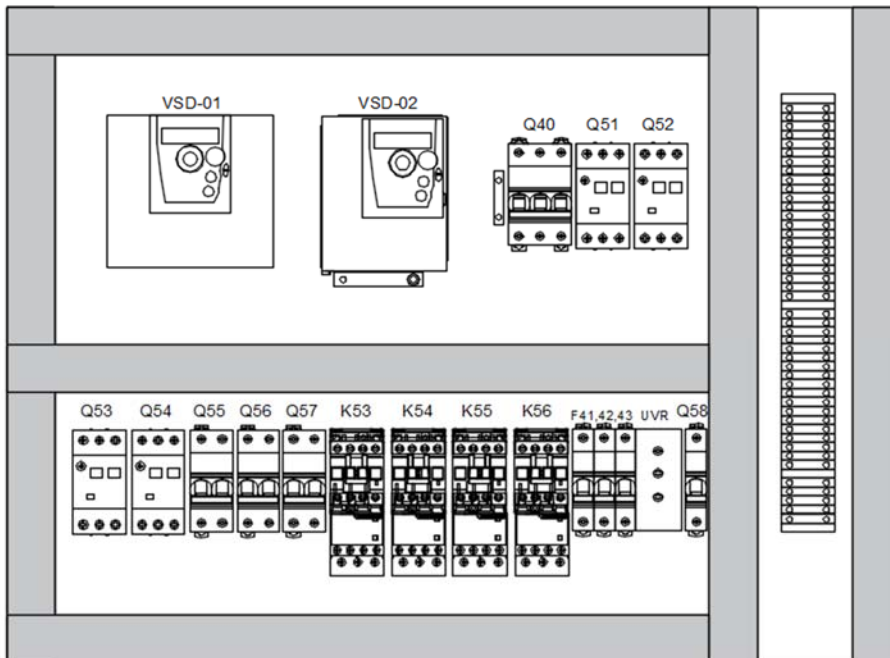

Figure 02

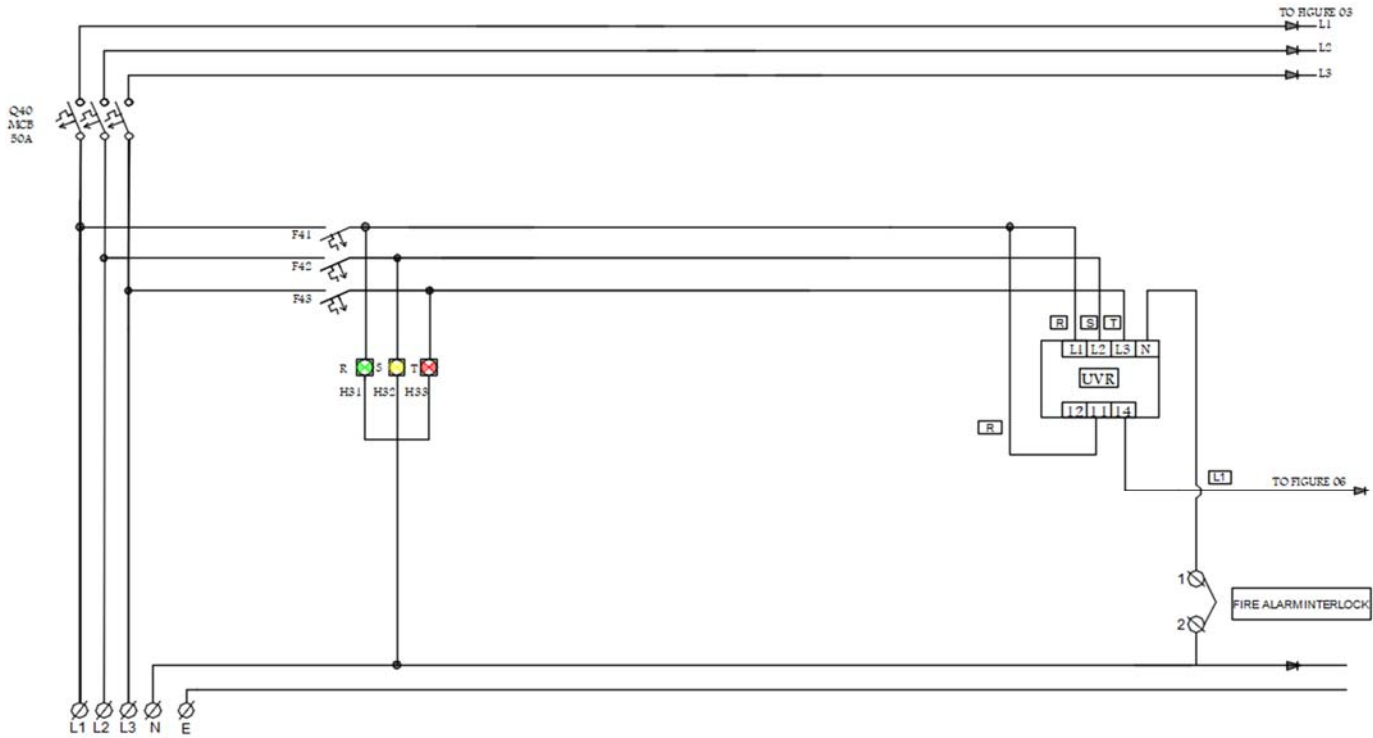

Figure 04

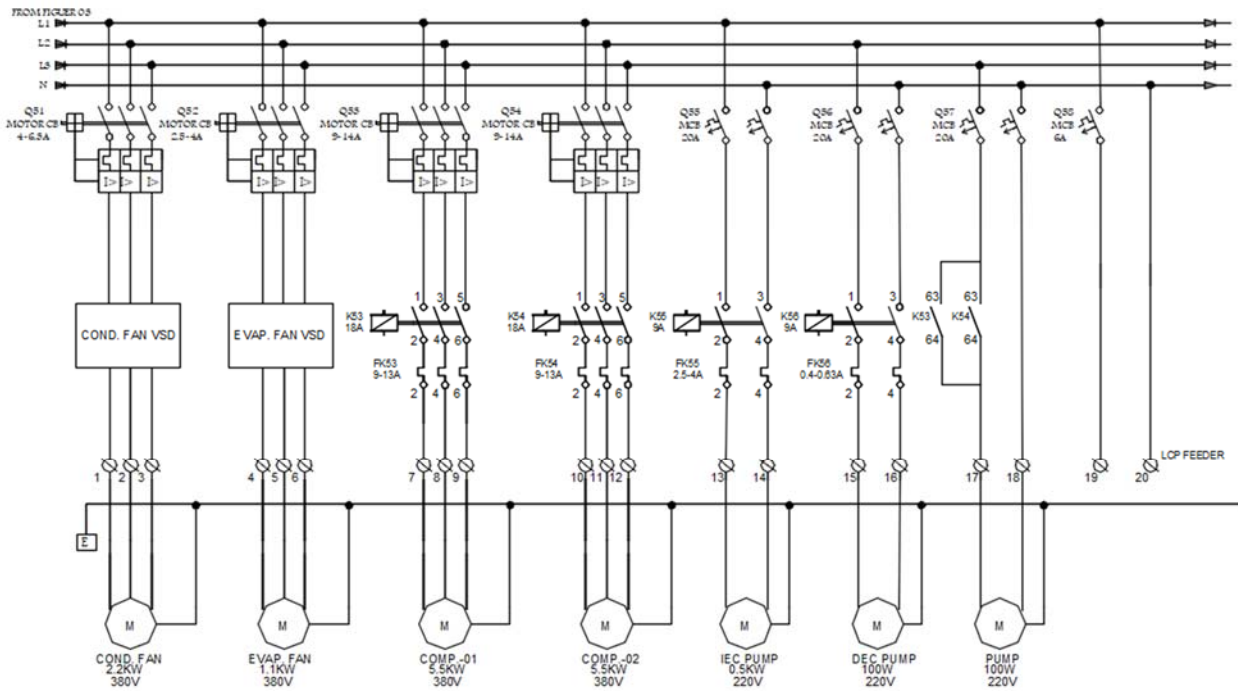

Figure 05

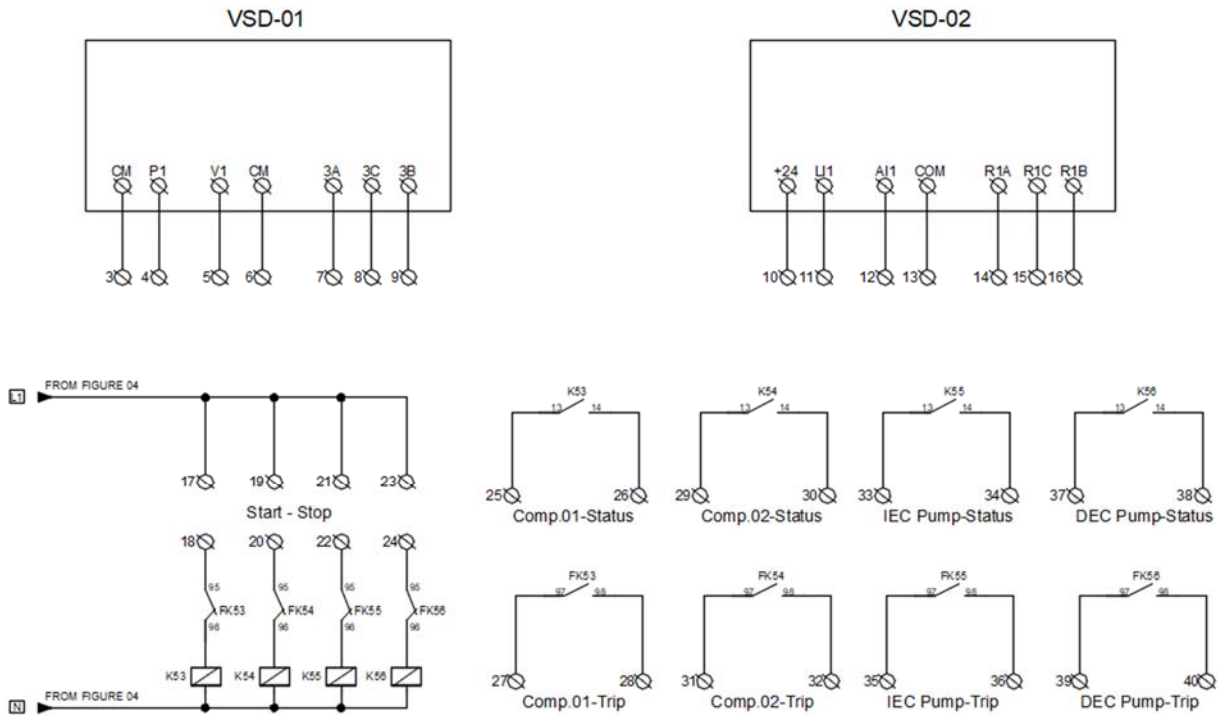

Figure 06

### B) LCP – Logical Control Panel

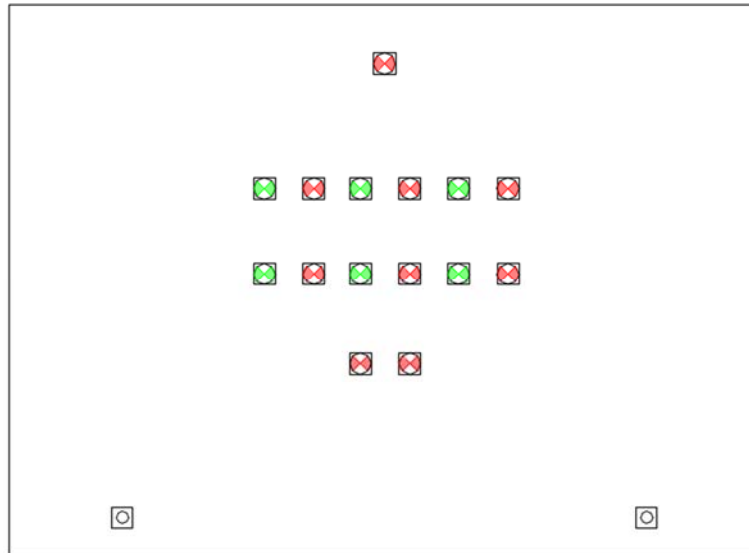

Figure 01

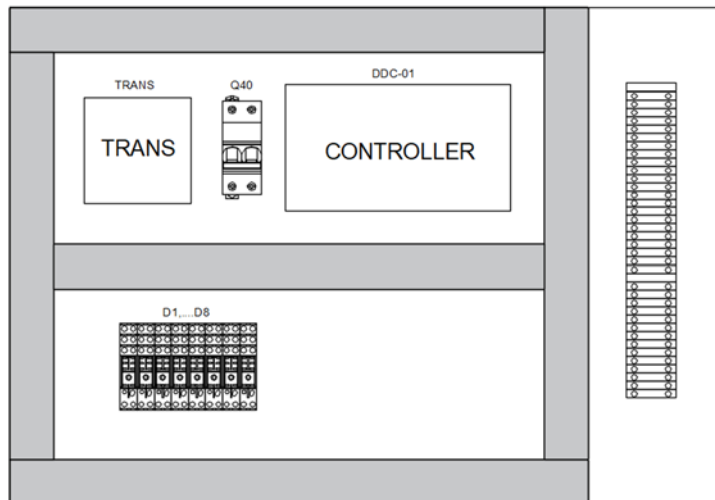
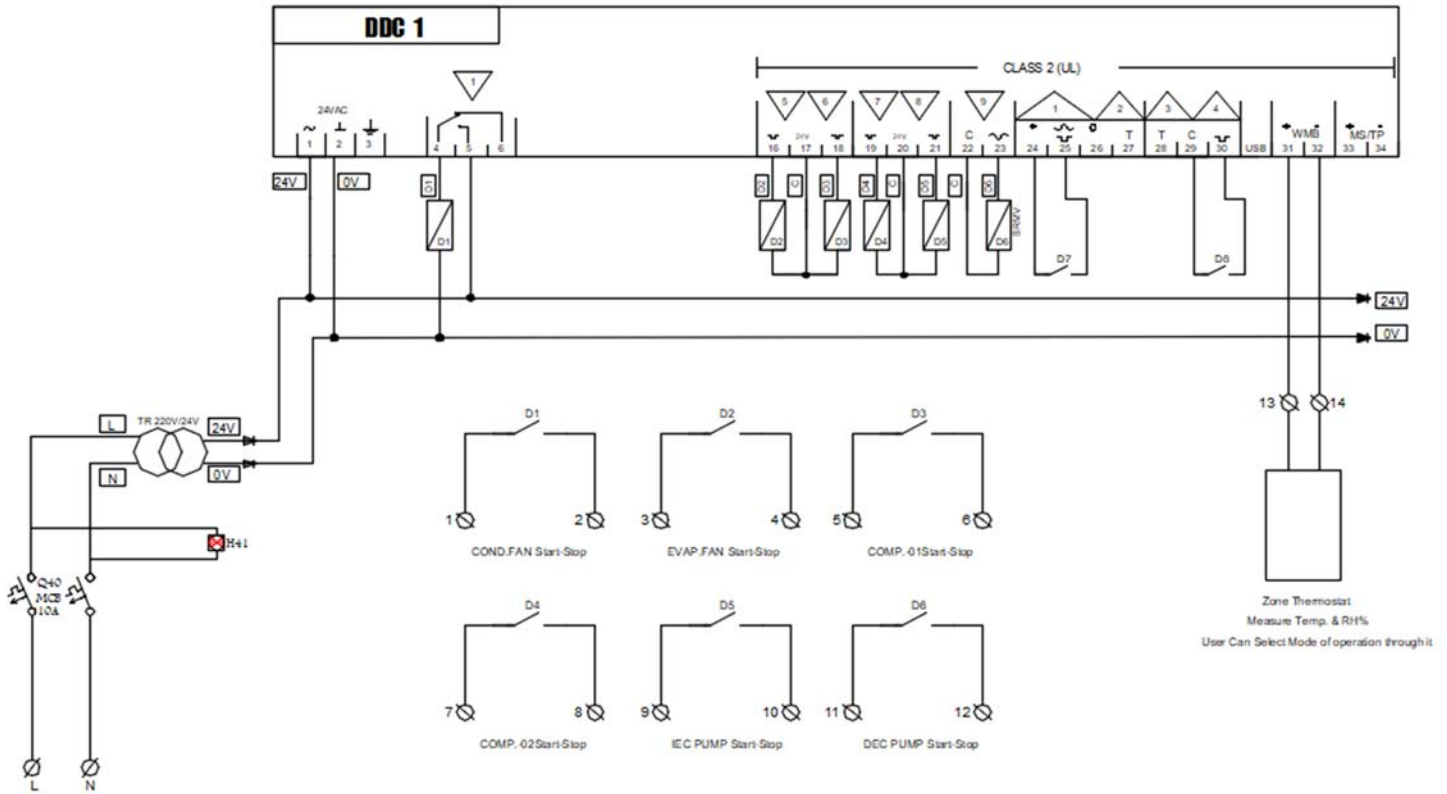

Figure 02

List of materials	
REF.	Serving
Q40	CONTROLLER
Transformer	
CONTROLLER	
D6	
D1,...8	Room Thermostat ( Temp. & RH% )
H41	INDICATIONS
H85,... Qty:14	

Figure 03



### LOWER CONNECTION TERMINAL

Figure 04

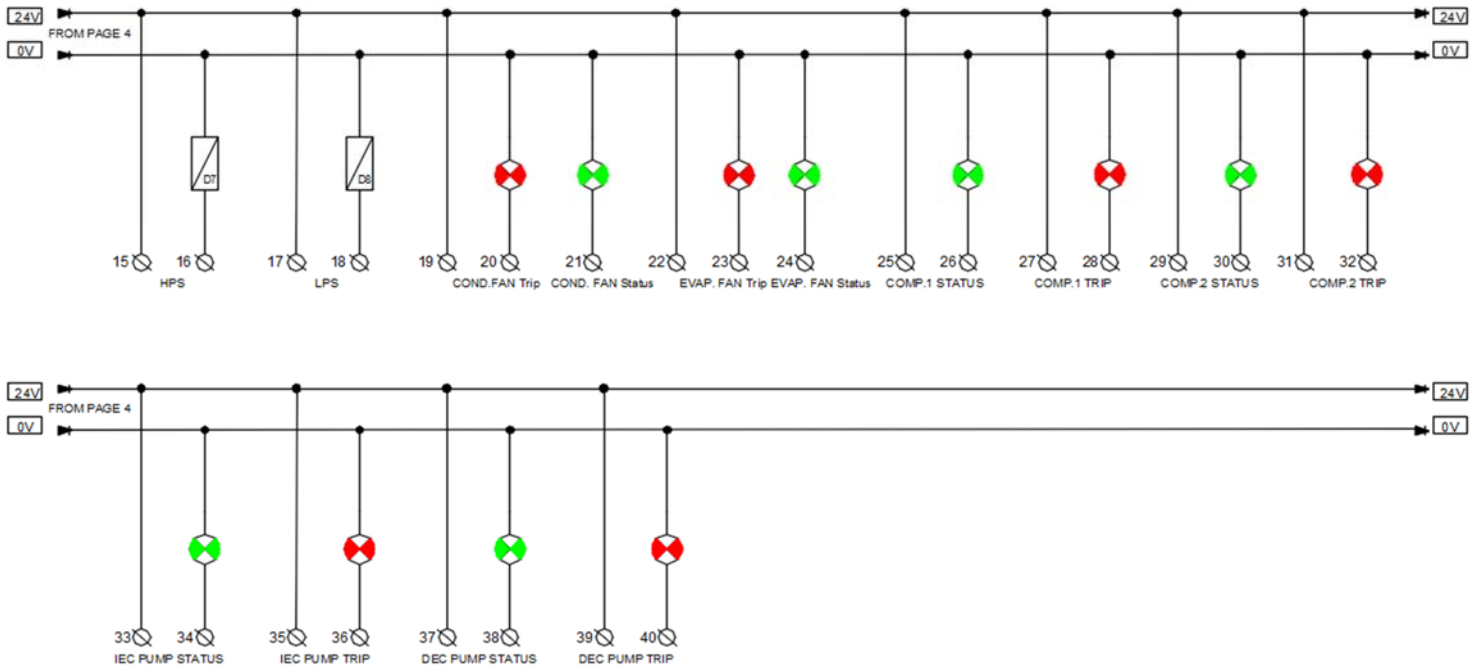

Figure 05

UPPER CONNECTION TERMINAL

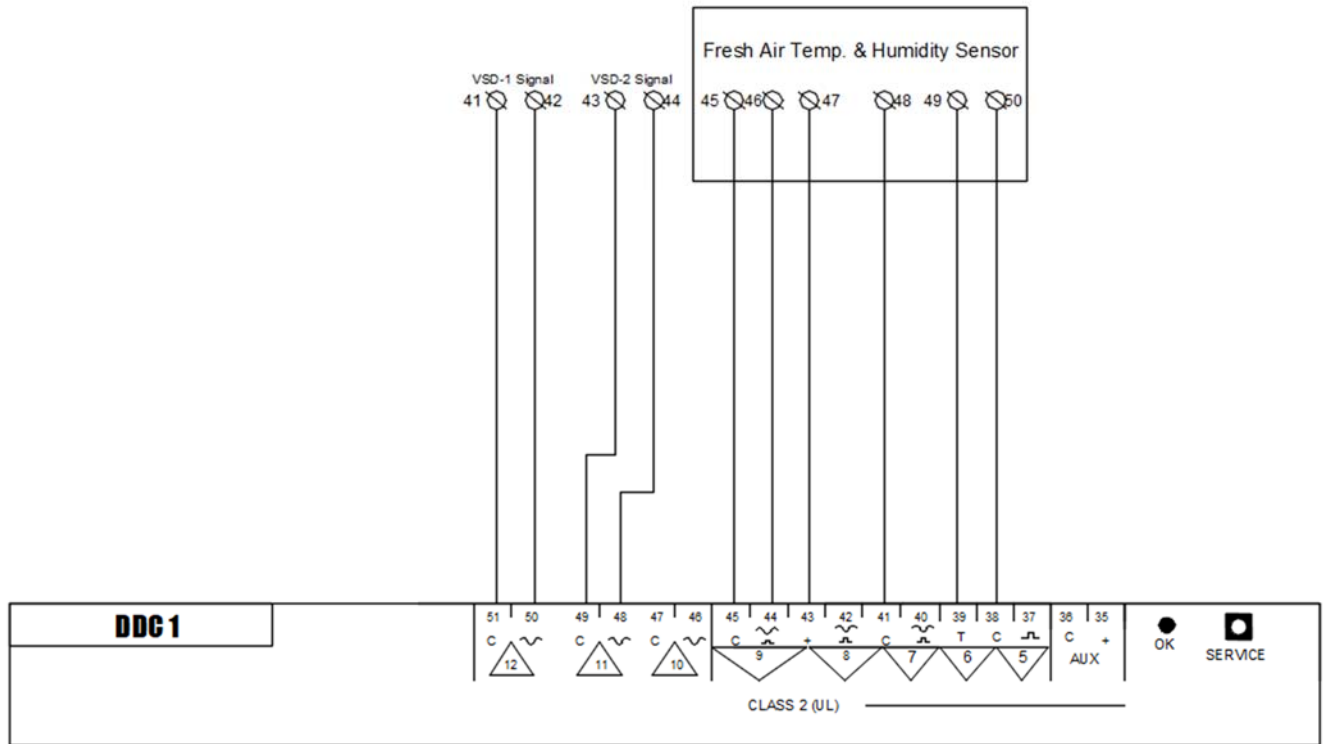

Figure 06

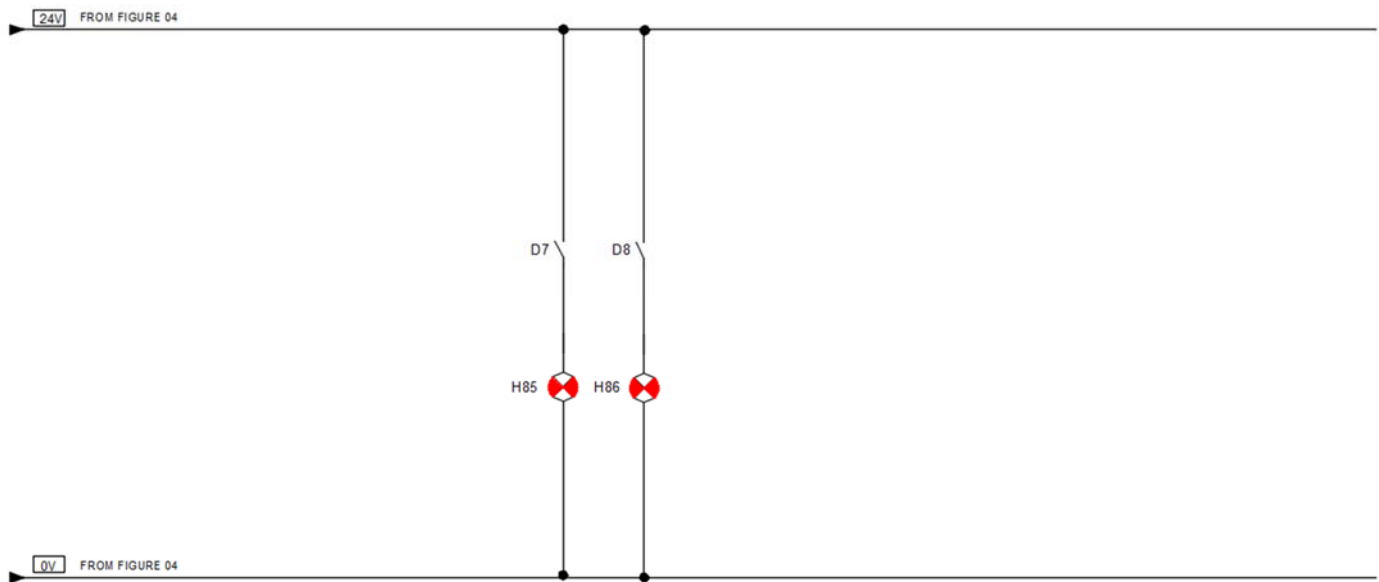
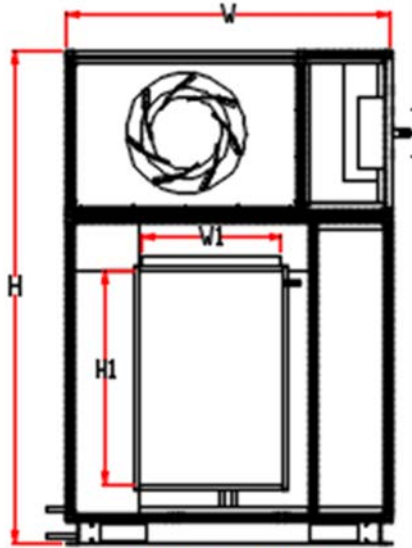

Figure 07

Dimensional Data

CG-HIDEc -54 & 81



SIDE VIEW-01  
PRIMARY AIR SIDE

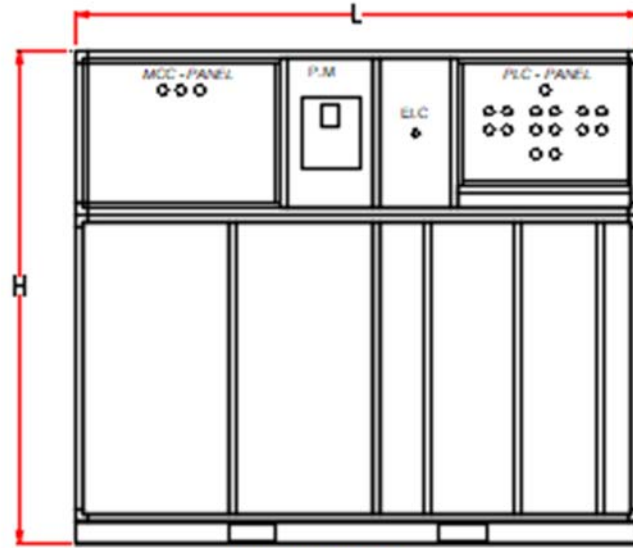

ELEVATION

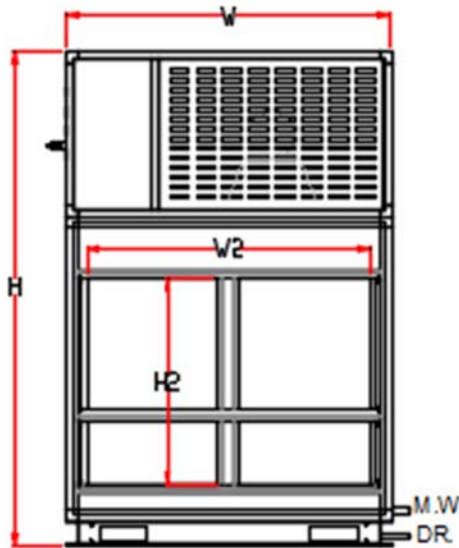

SIDE VIEW-02  
SECONDARY AIR SIDE

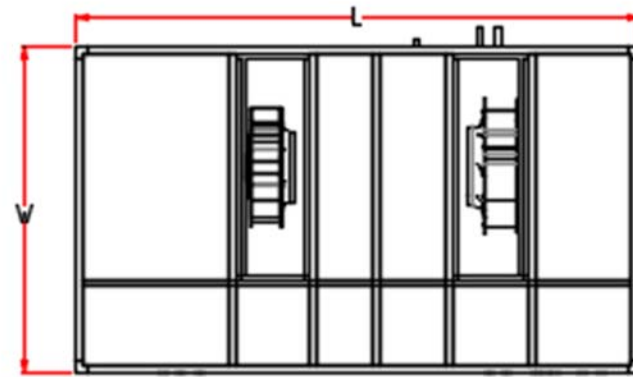

TOP VIEW

Dimensions Table

Series model	L	W	H	W1	W2	H1	H2	DR.	M.W
CG-HIDEc -54	2.4	1.4	2.1	0.6	1.2	0.9	0.9	25	19
CG-HIDEc - 81	2.4	2.0	2.2	0.9	1.8	0.9	0.9	25	19

\* Units in "m"

\*\* Drain and Make up water in "mm"

P.M : Power Meter  
EL.C : Power Cable

M.W : Make Up Water  
DR. : Drain pipe

CG-HIDEC - 108

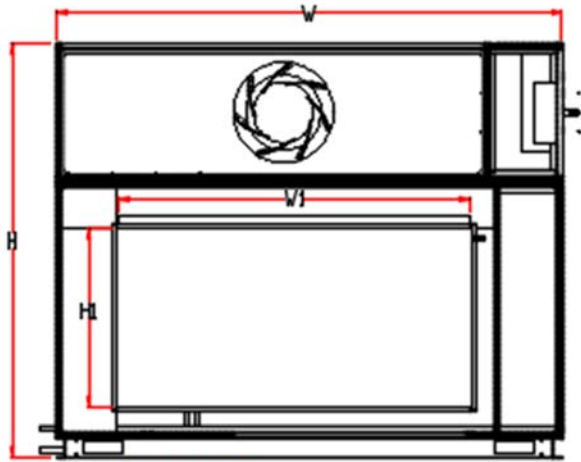

**SIDE VIEW-01**  
**PRIMARY AIR SIDE**

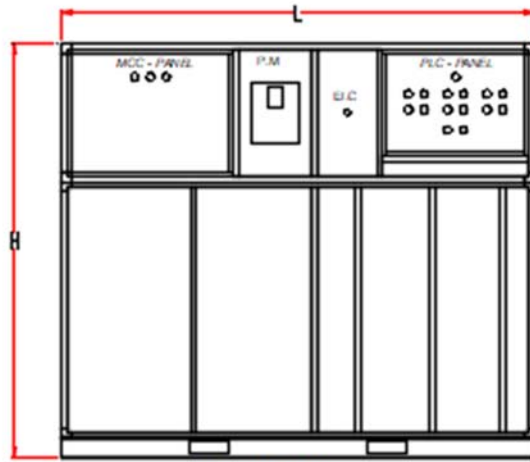

**ELEVATION**

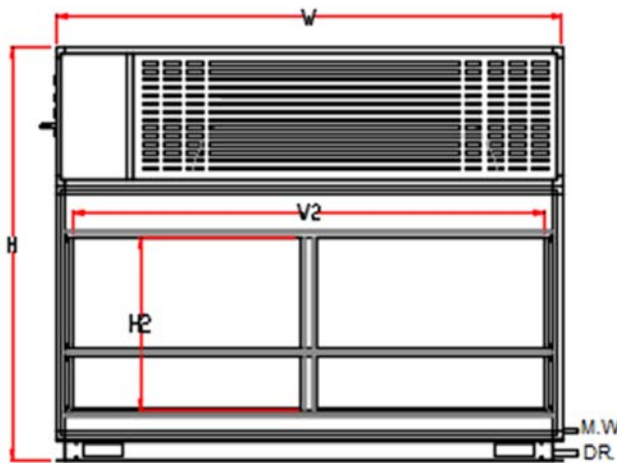

**SIDE VIEW-02**  
**SECONDARY AIR SIDE**

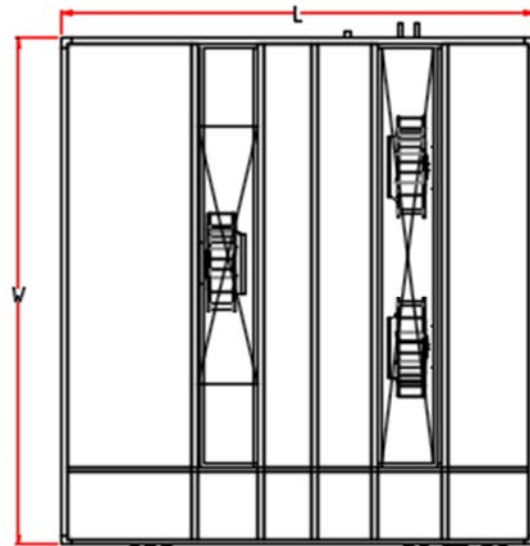

**TOP VIEW**

### Dimensions Table

Series model	L	W	H	W1	W2	H1	H2	DR.	M.W
CG-HIDEC - 108	2.4	2.6	2.2	1.2	2.4	0.9	0.9	32	25

\* Units in "m"

\*\* Drain and Make up water in "mm"

CG-HIDEC -162 & 216

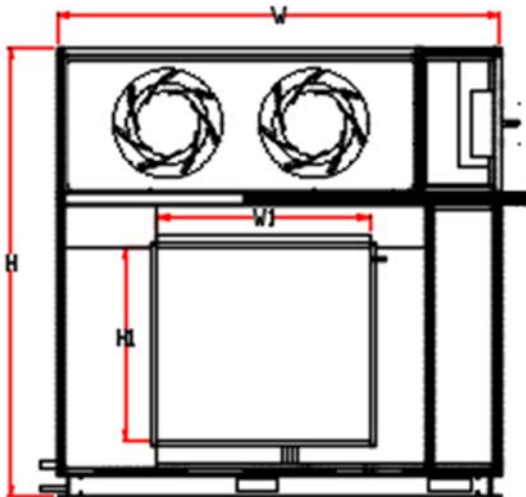

SIDE VIEW-01  
PRIMARY AIR SIDE

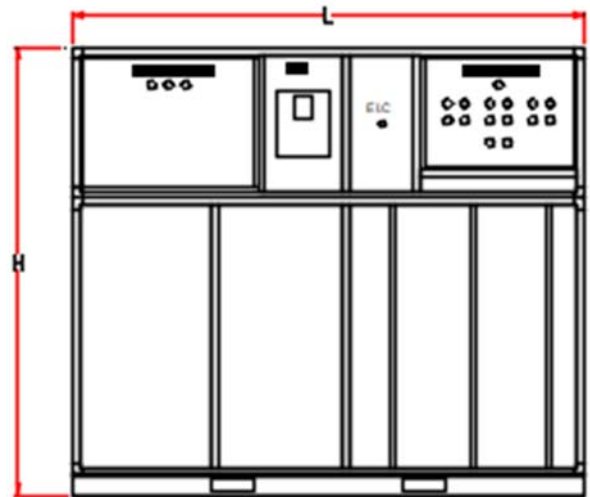

ELEVATION

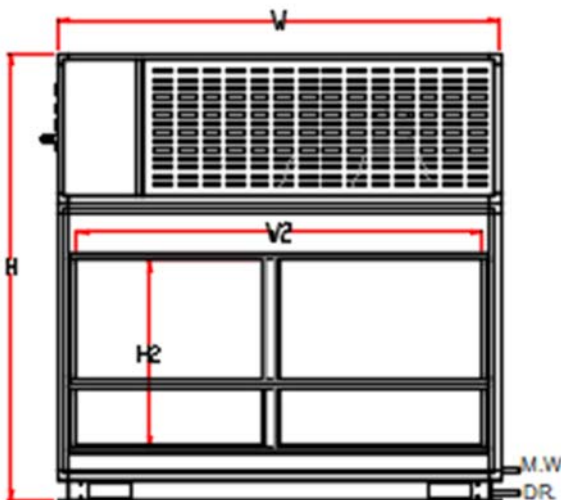

SIDE VIEW-02  
SECONDARY AIR SIDE

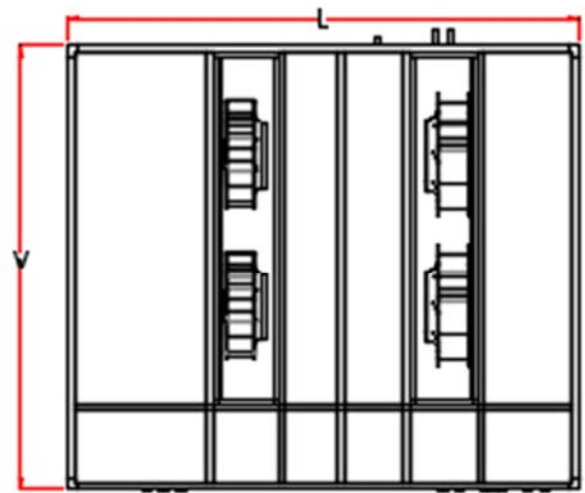

TOP VIEW

Dimensions Table

Series model	L	W	H	W1	W2	H1	H2	DR.	M.W
CG-HIDEC - 162	2.6	3.8	2.2	1.8	3.6	0.9	0.9	40	32
CG-HIDEC - 216	2.6	4.8	2.2	2.4	4.6	0.9	0.9	50	40

P.M : Power Meter      M.W : Make Up Water  
EL.C : Power Cable      DR. : Drain pipe

\* Units in "m"

\*\* Drain and Make up water in "mm"

### CG-HIDEC Cooling Performance Summary in according to Annual Simulation Analysis - Egypt's Climate Zones

Egypt's Climate Zones	Peak Load Performance				Annual Performance					
	Ambient Conditions (user Defined)		Power Cons. Rate	Water Cons. Rate	Operating Hours	Average Ambient DB Temp	Cooling Capacity Rate	Stand Alone IDEC Sharing Hrs	Power Cons. Rate	Water Cons. Rate
	DB °C	WB °C	Kw/RT	L/H/RT						
2: Delta and Cairo (CAIRO)	40	25.4	<b>0.8</b>	1.25	4,465	<b>27</b>	12.8	38	<b>0.75</b>	46.0
3: North Upper Egypt (BANI-SWAIF, MINYA)	42	24.6	<b>0.78</b>	1.35	4,463	<b>28.5</b>	12.5	40	<b>0.68</b>	55.8
4: Sothern Upper Egypt (ASYUT, SUHAG, QENA)	43	23.8	<b>0.75</b>	1.47	4,410	<b>29</b>	11.3	78	<b>0.37</b>	68.0
5: Eastern Coast (HURGUADA)	42	25.8	<b>0.81</b>	1.31	5,154	<b>30</b>	14.4	48	<b>0.64</b>	66.0
6: High Heights (EI-TOR)	39	26.1	<b>0.86</b>	1.13	5,091	<b>26</b>	15.0	30	<b>0.84</b>	41.8
8: South of Egypt (ASSWAN, LUXOR)	46	22.6	<b>0.59</b>	2.8	5,158	<b>32</b>	14.8	95	<b>0.21</b>	96.6

#### Notes

- Annual simulation based on based on 15 daily working hours, starting from 8 am with 18°C minimum ambient DB temperature (Cooling Mode).
- IDEC sharing hrs %, The percentage of number of hours that the IDEC cooling stages could achieve the desired supply air dew point temperature without need of activation the DX-refrigeration circuits.

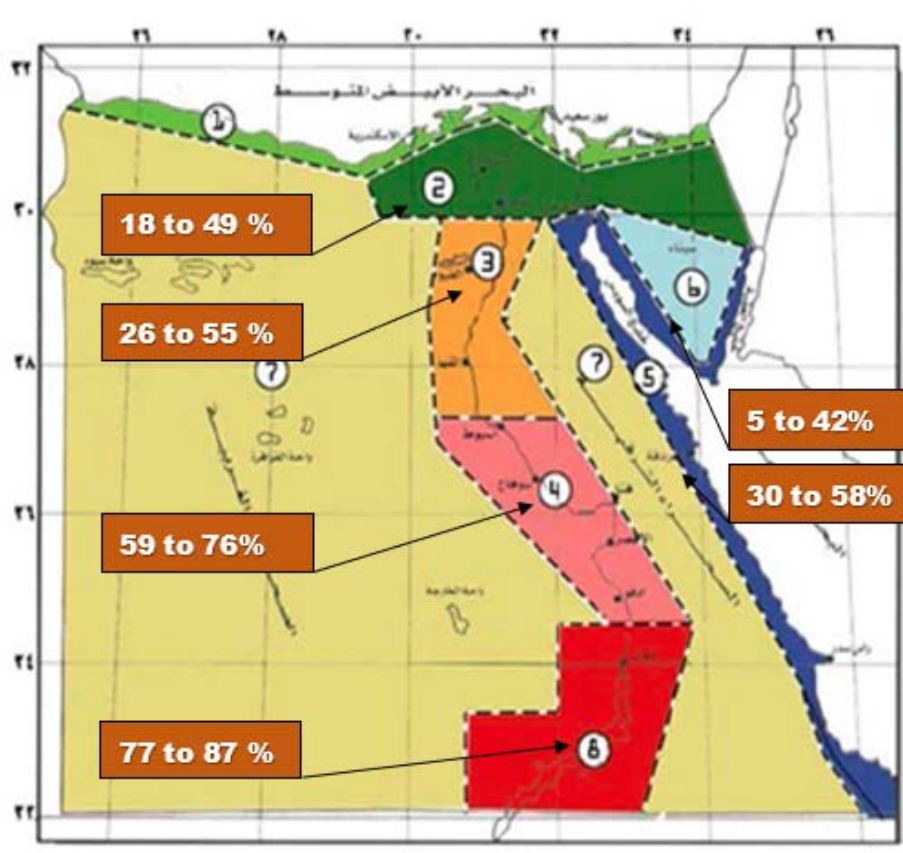

Average of Annual Power Savings % of CG-HIDEC In  
Comparing with The Conventional A/C System

Smart Sustainable Air Technology



Clima Green

## S. S. Air Technology

Address: Karnaval Industrial Complex 3<sup>rd</sup> Industrial Zone - 6 Of October Unit # 1123

[Sales@Sma-Technology.com](mailto:Sales@Sma-Technology.com)

+201094060138