



# 100 % Full Fresh Air Pro-Cool Unit

Two Stages Indirect / Direct Evaporative Cooling  
**CG – IDEC – 2S Series**



### *Meet and Comply With*

- ASHRAE Standard 62.1
- ASHRAE Standard 90.1
- ASHRAE STD 143

- Efficient Cooling Performance
- The Best Of IAQ "Indoor Air Quality"
- Cut Of Electricity up to 90 %
- Environment Friendly.
- Less Co2 Emissions
- Cost Effective Solution
- Superior Performance in Hot and Dry Climates
- Outdoor Installation.
- Significant Improving in GWP
- Anti Corrosive Construction.



## Two stages IDEC - Indirect / Direct Evaporative Cooling Unit

CG – IDEC- 2S Series

### Buildings / Owner Needs

All Building applications need fresh air to achieve the IAQ - Indoor Air Quality In according to the standard and code requirements.

S S Air Technology “Smart Sustainable Air Technology” present Clima Green products of high efficient cooling performance of 100 % Full Fresh CG – IDEC – 2S series “Two Stages Indirect Direct Evaporative units”.

Since the fresh air-cooling load represent significant part of the overall air condoning system, it is mandatory to find a way to reduce this capacity by means of high-cost energy recovery system or dedicated out door air central unit.

The 100% full fresh air of CG – IDEC – 2S technology provides the efficient cooling performance in comparing with the traditional Air to Air Energy Recovery devices, CG – IDEC – 2S secure much pressurization air effect to the building as the unit work without return air, moreover it provides significant cut of overall cooling tonnage of the air conditioning system depending on the fresh air percentage and the ambient conditions.

The derive cooling force for the CG – IDEC - 2S units is the multi stages indirect / direct evaporative cooling utilizing the wet bulb depression through different stages, in most cases, and depending the dryness of ambient conditions, the unit could able to secure the desired pre-cooling of fresh air as specified in 2019 - ASHRAE STD-62.1 for the maximum accepted dew point temperatures as 60 °F "15.5 °C".

### Why Clima Green CG – IDEC – 2S units??

Clima Geen IDEC – 2S units fulfill the buildings / Owner needs, it provides affordable and cost-effective 100 % full frsh air of Two Stages Indirect / Direct Evaporative Cooling unit cutting the overall system air cooling capacity and reducing the initial cost, however fulfilling the code and standard regulations such ASHRAE Standard requirements, indoor thermal comfort, energy saving and environmental control.

### Benefit's

Indoor air quality, Thermal Comfort, Energy Savings, Environmental Control and Cost Effective.

- Maximizing the fresh air, IAQ in according to Egyptian code regulation, meet and exceed the ASHRAE STD-62.1.
- Provide indoor Healthy environment improving the human activities.
- Reduce and optimizing the overall air conditioning cooling capacity.
- Electricity cut of energy and less power consumption.
- Lowest initial cost of the units, suit the affordable energy saving approach.
- Less co2 emission and GWP of the overall air conditioning system.
- Less maintenance and operation cost.
- Durable construction and more life span.
- Suitable for the new and existing construction applications.
- No risk of cross air contaminant or infection disease transfer.

### CG-MIDEC-Pro series Construction Concept

Clima Geen CG-IDEC- 2S units consist of two sections, fully separated as to independent air passage enclosures.

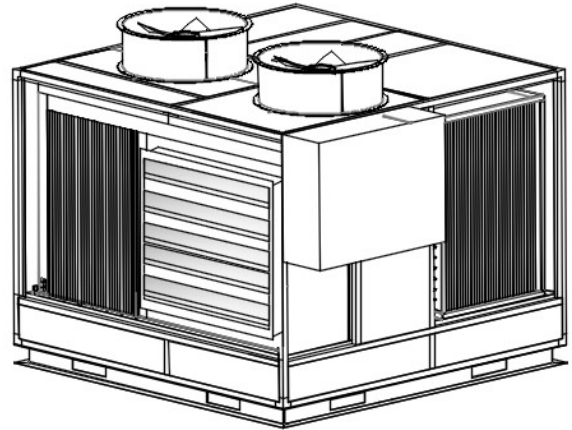
#### The first section "Primary Air"

Comprise the primary air supply fan, the IEC water cooling coil and evaporative post cooling pads.

#### The second section "Secondary Air"

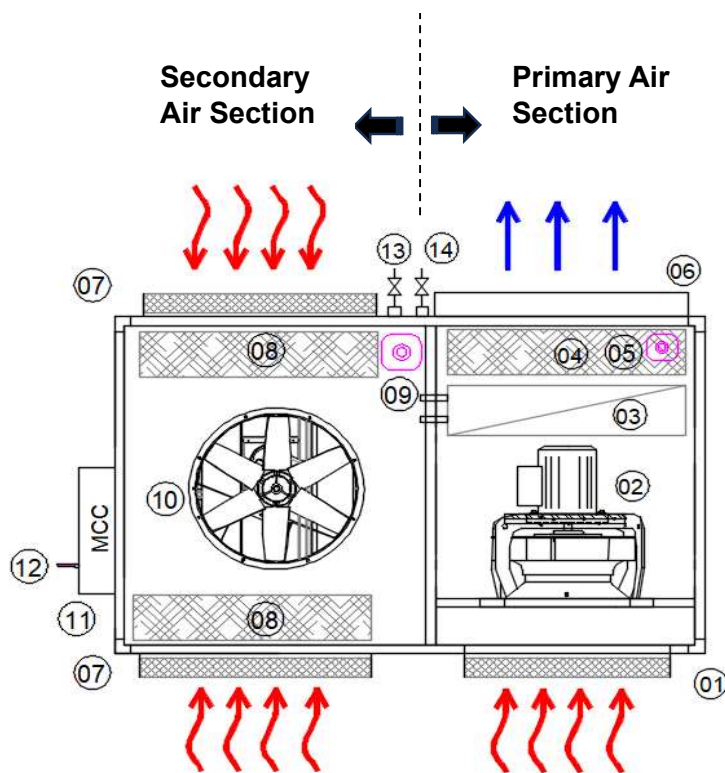
Comprise the exhaust fan, the adiabatic evaporative cooling pads, recirculating pumps.

*Important, The Primary air path enclosure is completely separate to the secondary air path, no risk of cross containment.*



- #### PRIMARY SECTION
- 01 PRIMARY INTAKE AIR FILTER
  - 02 SUPPLY AIR FAN
  - 03 1ST STAGE IEC WATER COIL
  - 04 2ND STAGE EVAPORATIVE COOLING PADS
  - 05 DEC - SUMP PUMP
  - 06 SUPPLY AIR DISCHARGE NECK

- #### SECONDARY SECTION
- 07 SECONDARY INTAKE AIR FILTER
  - 08 EVAPORATIVE COOLING PADS
  - 09 IEC - SUMP PUMP
  - 10 EXHAUST AIR FAN
  - 11 CONTROL PANEL
  - 12 ELECTRICAL FEEDER
  - 13 MAKE UP WATER VALVE
  - 14 DRAIN/OVER FLOW VALVE



**TOP VIEW**



## Two stages IDEC - Indirect / Direct Evaporative Cooling Unit

CG – IDEC- 2S Series

### CG-IDEC-Pro series Working Principles

The unit designed to provide 100% full fresh air as filtered and treated precooling supply air through stand-alone unit, through two stages indirect / direct evaporative cooling process.

#### Primary Air process

The cooling process consists of Multi stages of cooling.

**Supply air cooling stage " Indirect / direct evaporative cooling " :** The supply air fan blower drawn the 100% intake fresh air filtered through pre- filter and then entering to the 1st stage IEC water cooling coil , the pre-cooled air that leaving the IEC coil it is sensible cooling process (no dehumidification occur), it is constant dew point process where no moisture add in the pre-cooled air, IEC water coil deliver the cold water from the evaporative cooling pads located in secondary air section through the recirculating DEC-pump, 2<sup>rd</sup> stage cooling through direct evaporative cooling wet pads provide post cooling with slightly adding moisture content.

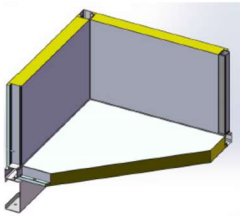
#### Secondary Air process

Secondary working intake air drawn by exhaust axial fan and air passing the evaporative cooling pads which cooled water and re-supplied the cold water to the 1st stage IEC water cooling coil in the primary air section via recirculating submersible IEC- pump.

### Unit Constructions

#### Panel Construction

Aluminum Profile - Anodized - Rockwall insulated sandwich panels for primary air-cooling section. While single skin aluminum



#### Drain Pans

Stainless Steel Drain pan with bottom pan drain hole sloped to side connection.



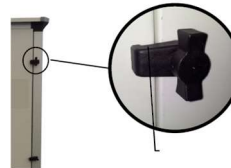
#### Base Frame

Epoxy Coated Heavy Duty black steel.



#### Profile Corners

Re-inforced Plastic / Nylon corners for aluminum profile connections



#### Door Lock

Door Lock in Nylon

#### Plug Fans

Primary / Secondary Supply air fans, High Efficiency non overloading high pressure backward Curved Centrifugal Plug Fan, Footed mounting, or Wall hanging, direct derive type, statically and dynamically balanced, Aluminum impeller complete with epoxy coated pedestal frame mounting in vibration isolators.



VFD, Variable frequency derive inverter to adjust the air flow against the actual fan static pressure, 0 to 10 v modulating speed control for part load power saving.

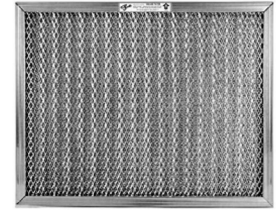
#### IEC Motors

premium efficiency - Aluminum Casing - anti corrosive coating squirrel cage induction motor, three phase standard IEC motor, insulation class - F, Efficiency class IE3, Ingress protection IP 54, continuous operation class S1



#### Air Intake Filter

Aluminum filters for large dust particles with aluminum frame and filter media in multi-layered flat aluminum wire, Washable. Class: G2, mounting: on slide rails or in frames, drawn to sides *through access panel*.  
*Optional Synthetic filter G4 grade.*



#### Water Cooling Coil

Copper tubes Aluminum fins air to water heat exchanger coil cooling coil. The collectors of the coils are equipped with nipples for vent and drain. The water coil have holes at the lower cover for the drainage of the condensate in the drain pan.  
*The coils, in standard execution, are subjected to a pneumatic test at a pressure of 30 Bar, by injection of dry air and water immersion.*



#### Coils Enclosures

The coils are housed in specific sections and individually mounted on "L" rails. For easy disassembly, at each coil corresponds a dedicated front panel. Seals of passage of the collectors EPDM exclusive design *to ensure a perfect air tightness and look perfectly smooth and easily washable inside the panel*. *The coil can be removed easily, leaving in place the gaskets.*

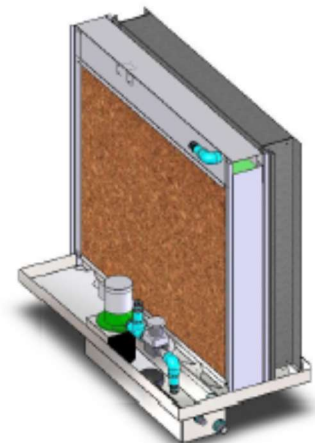


#### Direct Evaporative Cooling Pads

*Cellulose paper with thickness 200 mm, flute 7 for primary air IEC water coil circuit, while thickness 200mm, flute 5 spacing for primary air post cooling*

*The wet adiabatic evaporative cooling with recirculated water is equipped with circulating pump and by-pass valve for regulating the flow of water to the wet deck. The tank has a lower sump in which are housed the pump with.*

*stainless steel mesh filter, the make-up floating valve, the overflow with the drain plug. The lower sump in the water basin allows to reduce the amount of water present in the basin and, resulting almost emptied at each switch over of the pump, ensures the necessary bleed -off (to reduce the concentration of salts in the water and ensure a periodical replacement of the same).*





## Two stages IDEC - Indirect / Direct Evaporative Cooling Unit

CG – IDEC- 2S Series

### Water Circulating Pump

*submersible type - stainless steel water circulating pump European certified,  
heavy-duty operation for long lifetime and minimum trouble shooting.*



### Electrical Components

*Miniature Circuit Breakers, Motor Circuits Breakers, Contactors, relays,  
overload, ..... VSD as an option*

Green  
Premium



Green  
Premium



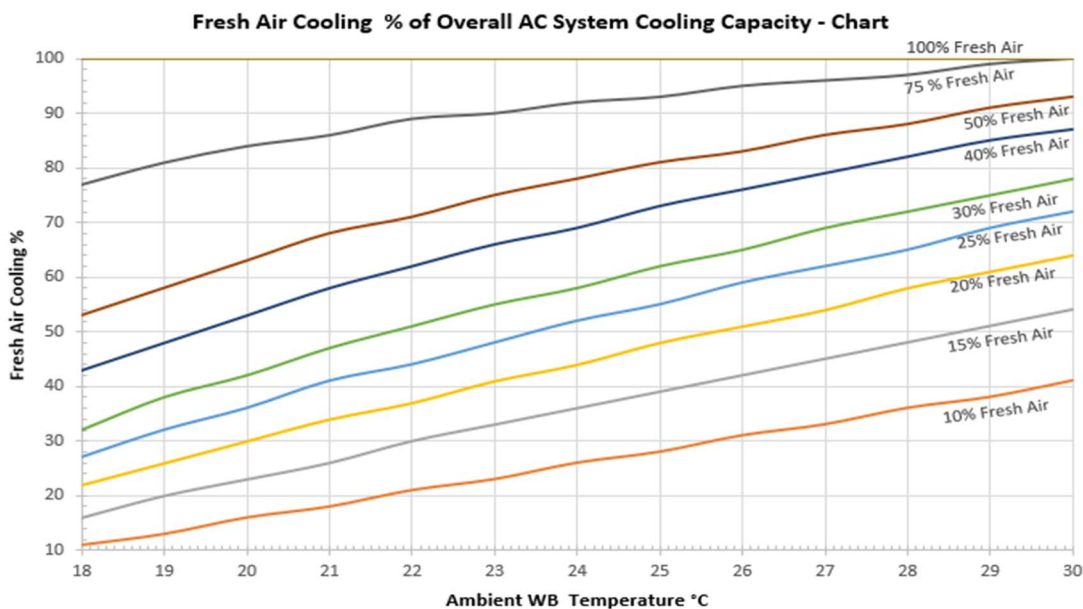
### Applications

All Buildings need fresh air as portion of supply air according to code and standard regulations. The fresh air-cooling load represents significant cooling percentage of overall air conditioning system peak demand. this percentage depend on the outdoor wet bulb temperature and the fresh air % of Supply air, Code of practice of administrative commercial buildings need around **10-20 %** fresh air % of supply air while high density occupation buildings as well as medical and clean rooms buildings need around **30-40 %** fresh air percentage of supply air.

*The below table and chart show the fresh air-cooling capacity % of overall Ac system peak cooling at different ambient wet bulb temperature and fresh air % of supply air.*

F.A % of Supp. Air %	Fresh Air Cooling % of total A/C system cooling Capacity												
	Outside Air - Wb °C												
	30	29	28	27	26	25	24	23	22	21	20	19	18
10	41	38	36	33	31	28	26	23	21	18	16	13	11
15	54	51	48	45	42	39	36	33	30	26	23	20	16
20	64	61	58	54	51	48	44	41	37	34	30	26	22
25	72	69	65	62	59	55	52	48	44	41	36	32	27
30	78	75	72	69	65	62	58	55	51	47	42	38	32
40	87	85	82	79	76	73	69	66	62	58	53	48	43
50	93	91	88	86	83	81	78	75	71	68	63	58	53
75	100	99	97	96	95	93	92	90	89	86	84	81	77
100	100	100	100	100	100	100	100	100	100	100	100	100	100

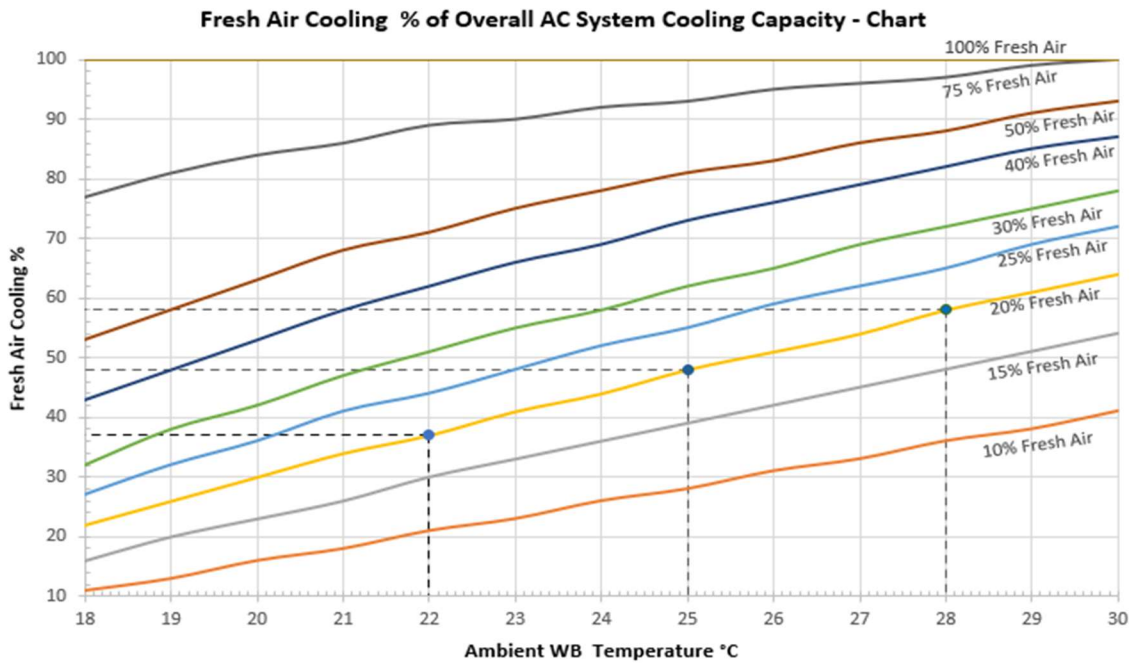
- The tabulated Cooling capacity % values calculated based on room temperature 24 °C and 50 % RH and supply air temperature 14 / 13.5 °C DB/WB
- Regardless the ambient dry bulb temperature, Fresh air-cooling capacity is depending on the ambient outside wet bulb temperature.
- Fresh Air-cooling Capacity as % of the A/C system cooling capacity increase at humid ambient at higher wet bulb temperature.
- Fresh Air-cooling Capacity as % of the A/C system cooling capacity in humid weather like in North coast at 27 °C WB is more than Cairo at 25 °C WB.
- For Example, in Cairo, @ summer 25 °C WB, where 20 % fresh air, the fresh air cooling represents 48 % of the total system cooling capacity required.
- \* Indirect Evaporative Cooling CG-IDEC-ERV reduce the Overall Ac cooling capacity by 24 % comparing with traditional direct outside air.
- \* CG-IDEC-ERV consume less power consumption than traditional A/C system, result in 19 % power savings of overall air-cooled AC / system power.
- \* CG-IDEC-ERV price cost rate is around 2.2 USD / CFM less than traditional (Commercial / Industrial) air conditioning units.



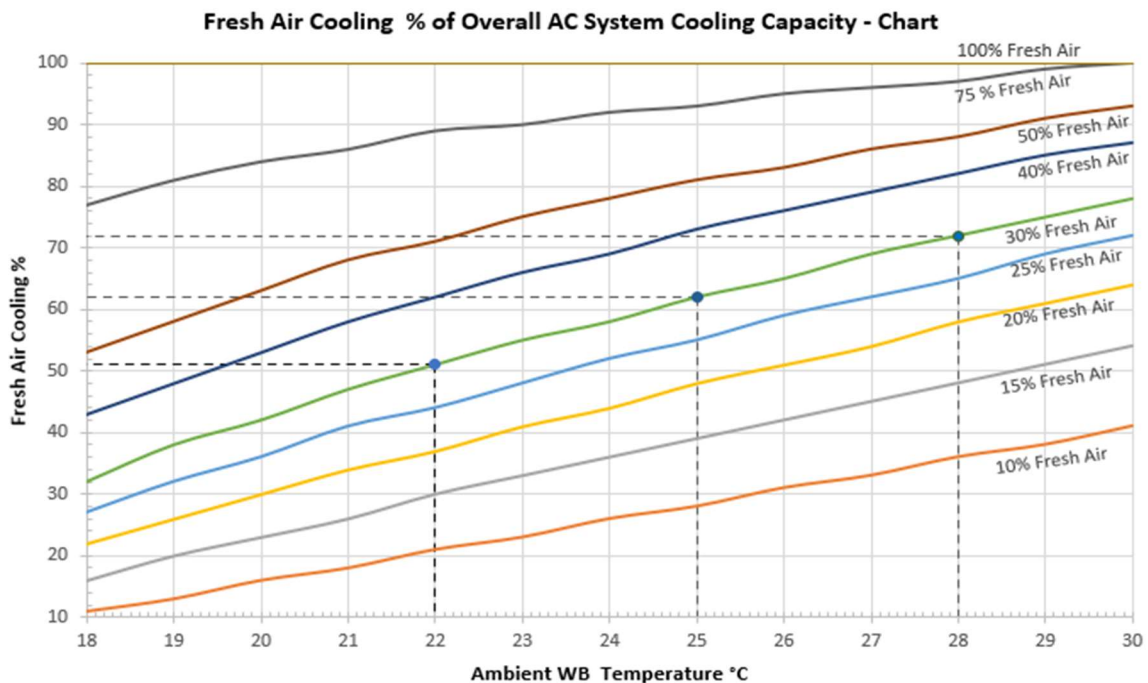
## Two stages IDEC - Indirect / Direct Evaporative Cooling Unit

CG – IDEC- 2S Series

*The Below example chart shows the fresh air-cooling capacity represent 37 to 58 % of overall Ac system peak cooling at different ambient wet bulb temperature (22, 25 and 28 °C) at fresh air 20% of supply air.*



*Another example chart shows the fresh air-cooling capacity represent 51 to 72 % of overall Ac system peak cooling at different ambient wet bulb temperature (22, 25 and 28 °C) while fresh air 30% of supply air.*



### Physical Data

Model Serial Number	CG-IDEC- 2S- 54	CG- IDEC- 2S - 81	CG- IDEC- 2S - 108	CG- IDEC- 2S - 162	CG- IDEC- 2S - 216
Nominal air Flow (m3/h)	5,400	8,100	10,800	16,200	21,600
(CFM)	<b>3,000</b>	<b>4,500</b>	<b>6,000</b>	<b>9,000</b>	<b>12,000</b>
Input Power Kw (STD/Hi) *	3.7 / 4.2	5.2 / 6.0	7.4 / 8.4	10.7 / 12.4	15.4 / 17.4
WBDE % (IEC stages / IDEC)	Up to 120				
EER (Btuh/watts) (IEC / IDEC)	UP to 44				
<b>IEC water Cooling Coil</b>					
Type	CU/ALU fins				
No of rows	8				
Face Velocity (m/s)	2.5 to 2.75				
Frame Coating	Epoxy				
Air Pressure Drop (pa)	160				
<b>IEC / DEC -Recirculating pump</b>					
Type	Submersible				
Material	Plastic Casing / Stainless Steel core				
Quantity (IEC/DEC)	2 / 1	2 / 1	2 / 1	2 / 1	2 / 1
Capacity (Kw)	0.55 / 0.1	0.75 / 0.1	1.1 / 0.15	1.5 / 0.37	2.2 / 0.55
Voltage	230/1/50		380/3/50		
<b>IEC - Evaporative Cooling - Pads</b>					
Type	Flute - 7				
Material	Cellulose paper				
Face Velocity (m/s)	2.5 to 2.75				
Area (m2)	0.55	0.75	1.1	1.5	2.2
Thickness (mm)	200				
Air Pressure Drop (pa)	120				
Efficiency (%)	80				
<b>DEC - Evaporative Cooling - Pads</b>					
Type	Flute - 5				
Material	Cellulose paper				
Face Velocity (m/s)	2.5 to 2.75				
Area (m2)	0.55	0.75	1.1	1.5	2.2
Thickness (mm)	150				
Air Pressure Drop (pa)	90				
Efficiency (%)	85				
<b>Primary - Supply Air Fan</b>					
Type	Plug Fan				
Nominal Air Flow (m3/h)	5,400	8,100	10,800	8,100	10,800
Quantity	1	1	1	2	2

### Physical Data continued

Size (mm)	450	500	560	500	560
Material	Aluminum				
Frame Coating	Epoxy				
Derive	Direct				
Speed	VFD (optional)				
Motor	IEC				
Power (STD/Hi) Kw- Each	1.1 / 1.5	1.5 / 2.2	3.0 / 4.0	2.2 / 3.0	3.0 / 4.0
Efficiency Class	IE3				
Insulation Class	F				
Ingress Protection	IP54				
<b>Secondary - Exhaust Air Fan</b>					
Type	Axial Fan	Axial Fan	Axial Fan	Axial Fan	Axial Fan
Nominal Air Flow (m3/h)	10,800	16,400	21,600	32,400	43,2000
Quantity	1	1	1	2	2
Size (mm)	630	710	710	630	710
Material	Aluminum				
Frame Coating	Epoxy				
Derive	Direct				
Speed	VFD (optional)				
Motor	IEC				
Power (STD) Kw- Each	1.5	2.2	2.2	1.5	2.2
Efficiency Class	IE3				
Insulation Class	F				
Ingress Protection	IP54				
<b>Filters</b>					
Type	Pre-filter	Pre-filter	Pre-filter	Pre-filter	Pre-filter
Material	Aluminum-Washable Flat type				
Face Velocity (m/s)	2.5 to 3.0				
Thickness (mm)	25	25	50	50	50
Air Pressure Drop (pa)	50	50	65	65	65
EU - Efficiency Grade	G4				
<b>Electrical / Control</b>					
Electrical Panel	Panel Components by Schnieder				
Operation Modes	1- Pre - Cooling, 2- Ventilation Mode				
Control Module	DDC - Controller - <b>Optional</b>				

- STD/Hi \*: Standard and Hi static duct applications.

- Unit could stable in duty working as much as outdoor temperature reaches 50 ° C.

### Selection Software:

Clima-pro ver.01 software, provide flexibility for the unit selection either standard or energy recovery, the weather data extracted from 2019-ASHRAE-Climate, the user could write different outdoor design conditions through user defined option, as well as supply air flow and the return air condition, and required room pressurization, the software provide all the air properties as well as process plotting in Psychrometric chart and cooling performance for each cooling stage. annual analysis also available in according to 2015- ASHRAE - IWEC "International Weather for Energy Calculations.

<b>Owner :</b> XXXXX	<b>Consultant:</b> XXXX	<b>Date:</b> September 23, 2025
<b>Project :</b> Sugar Cane	<b>Contractor:</b> EMDAD	<b>Rev. :</b> 0
<b>DESIGN DATA</b>		
<b>Unit Tag:</b> IDEC	<b>Qty:</b> 1	<b>BLDG.#</b> XXXXX
<b>Air Flow</b> 3,070 L/s	<b>C. Cap.</b> 59 Kw	<b>Sup.temp</b> 28 °C
<b>ESP</b> 100 Pa	<b>16.8 RT</b>	<b>E.Power</b> 23.6 Kw
		<b>EER</b> 8.6 Btuh/w
<b>SELECTION</b>		
<b>2019 Ashrae Climates</b>		<b>Design</b>
	Summer Cooling	Evaporation
<b>Country</b> EGYPT	Latitude 24.0	0.4 % DB/MCWB
<b>City</b> ASSWAN	Elevation 202	44.3 20.9
	22.6	40.6
		Ambient Air
		DB WB
		44.0 22.5

### Clima Green Two Stages Indirect / Direct Evaporative Cooling unit - 100 % Full Fresh Air CG-IDEC-102

<b>STD Air Flow :</b> 3,000 L/s	<b>ESP</b> 250 Pa	<b>Power :</b> 7.5 Kw	<b>IEC/IGD</b>
<b>Intake Air</b> 6,000 L/s		<b>Dimension</b>	
<b>Exh. Air</b> 3,000 L/s	<b>ESP</b> Pa	<b>Weight :</b>	

#### Supply Leaving Condition:

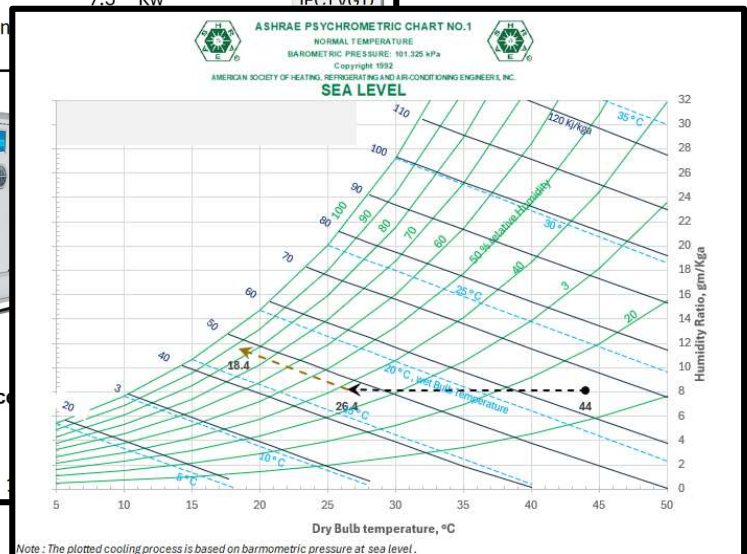
<b>DB</b>	18.4 °C
<b>WB</b>	17.0 °C
<b>W</b>	0.0116 Kg/Kga
<b>RH</b>	87.15 %
<b>H</b>	47.9 Kj/Kga
<b>ρ</b>	1.20 kg/m3
<b>DP</b>	16.3 °C



Note: Modulate the Supply Air flow via VSD inverter 3070 L/S **CG-IDEC-102**

#### Cooling Performance

<b>Sensible Cooling</b>	93 KW	26.5 RT	<b>S.COP</b>
<b>Total Cooling</b>	64 KW	18.2 RT	<b>T.COP</b>
<b>Water Cons.</b>	136 L/h		<b>WBDE</b>



### Electrical wiring and Control

Sample wiring diagram for model # CG-IDEC-2S-162

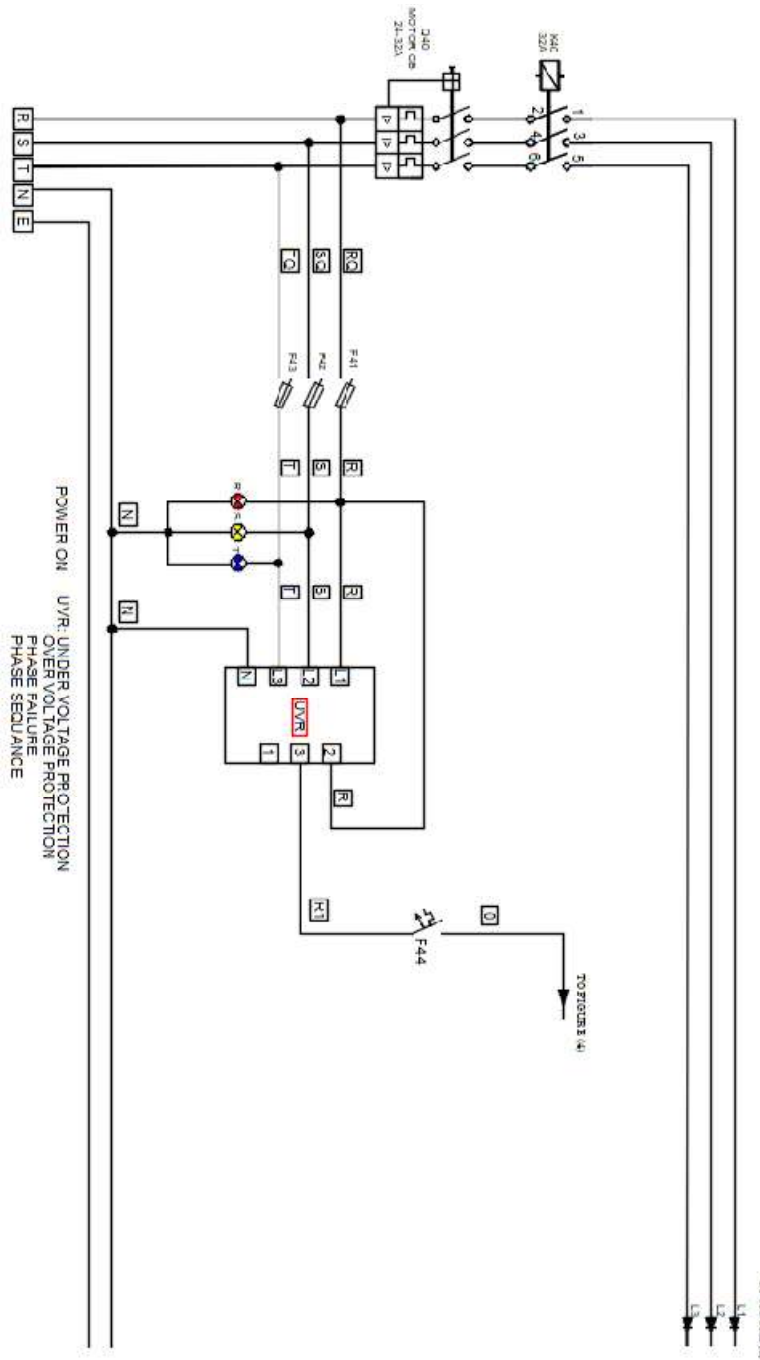
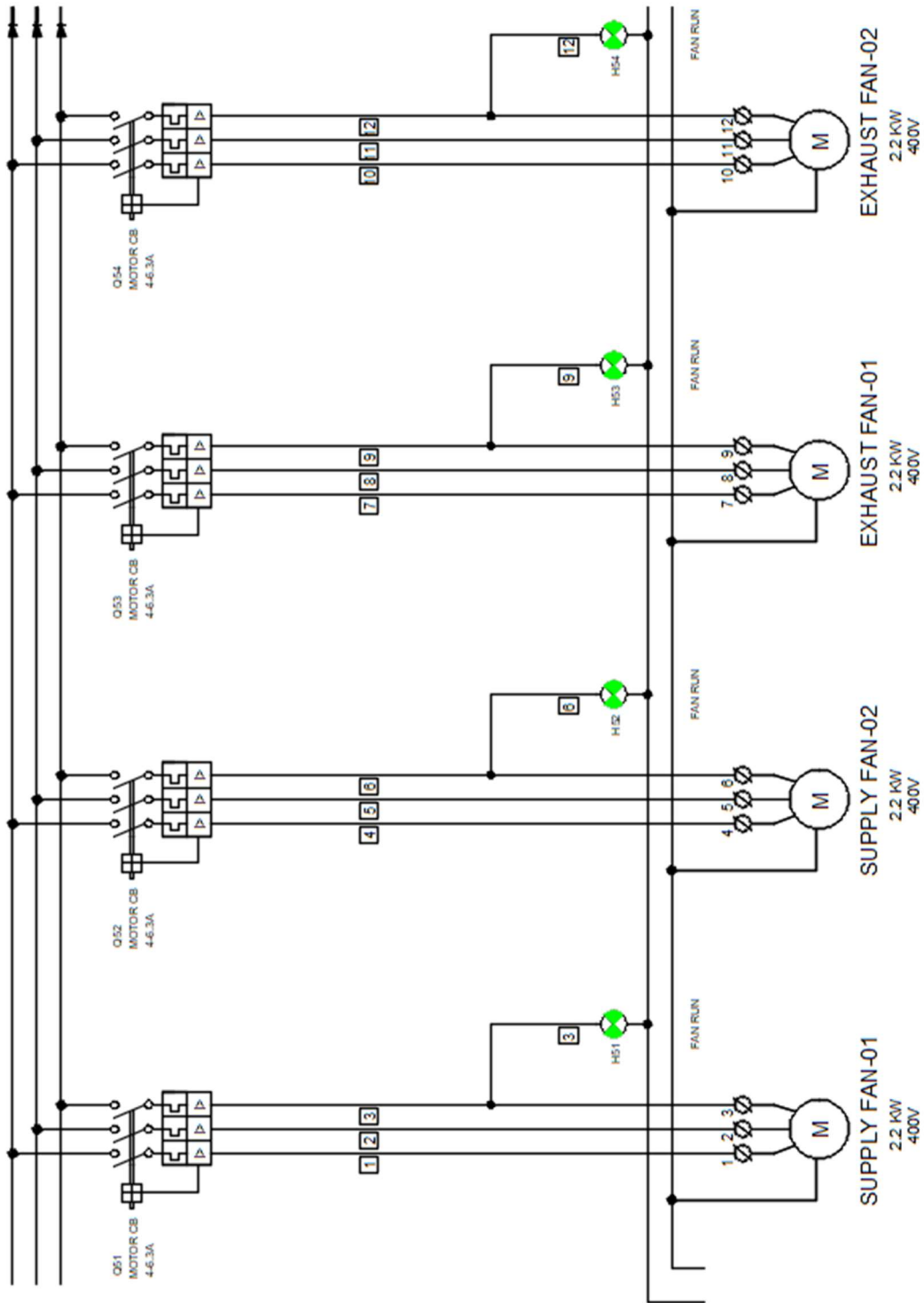
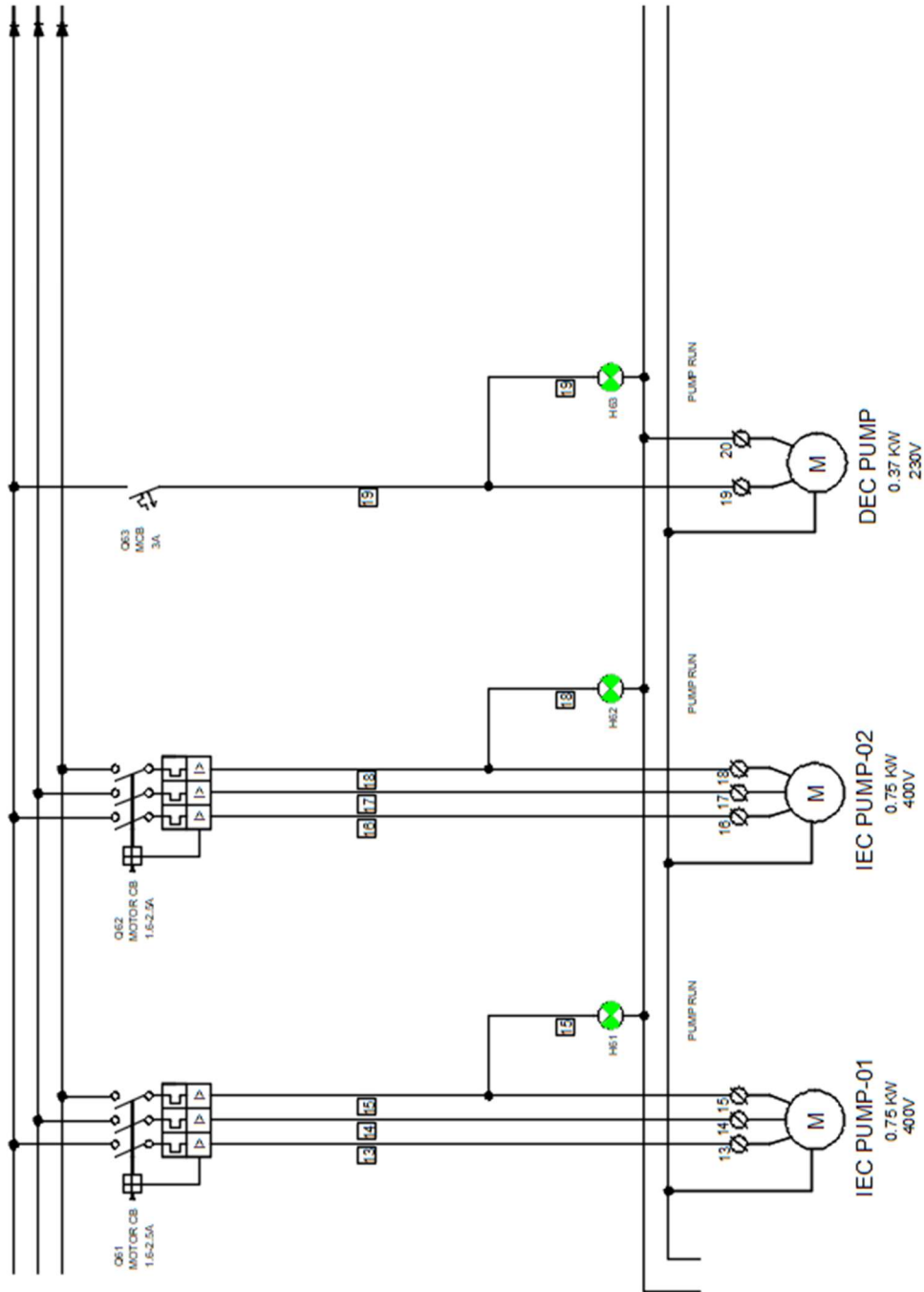


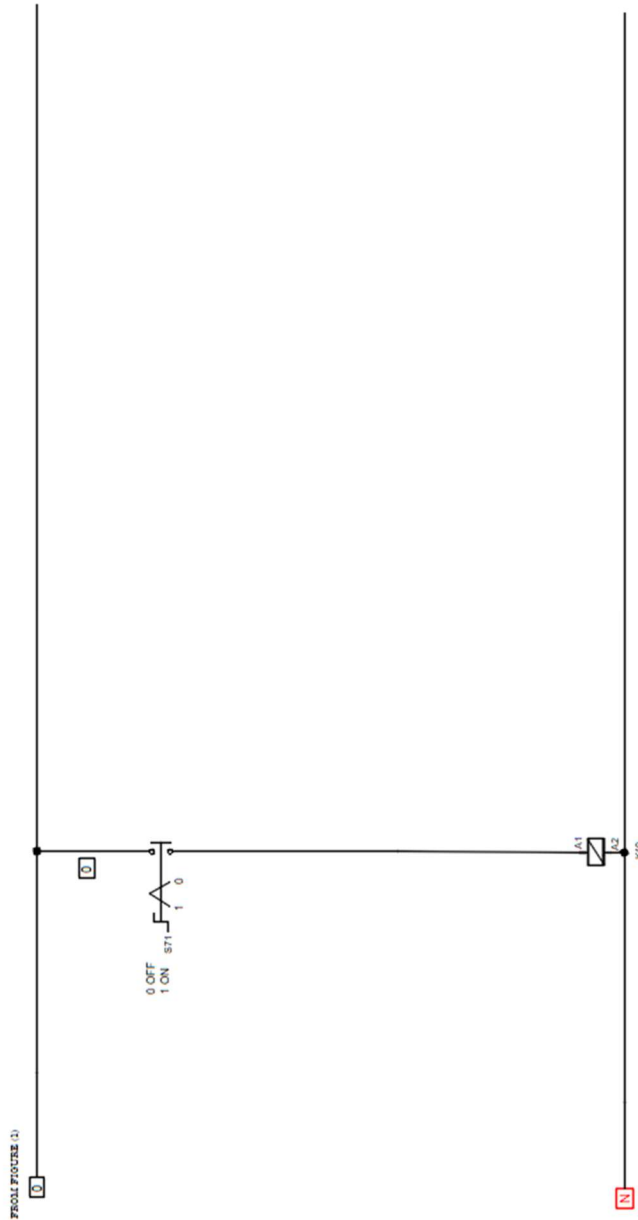
Figure 01



**Figure 02**

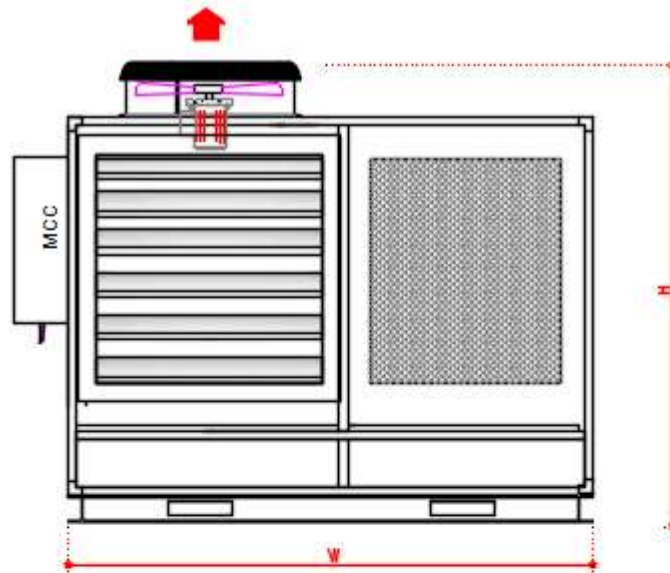


**Figure 03**

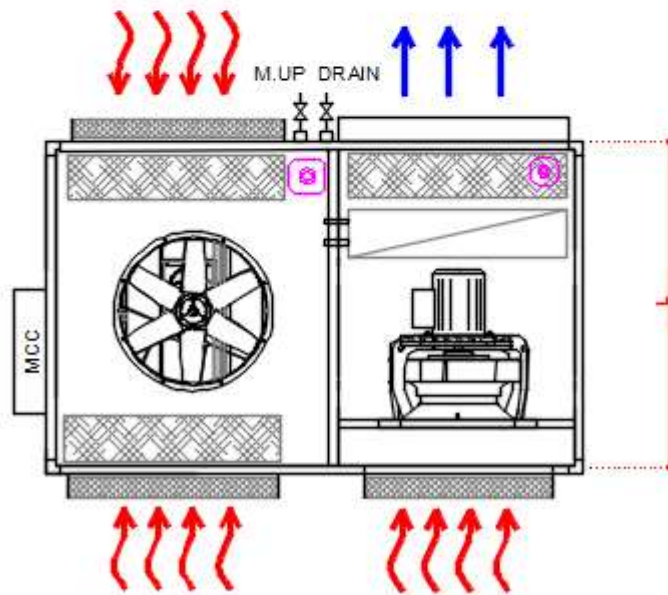


**Figure 04**

Dimensional Data



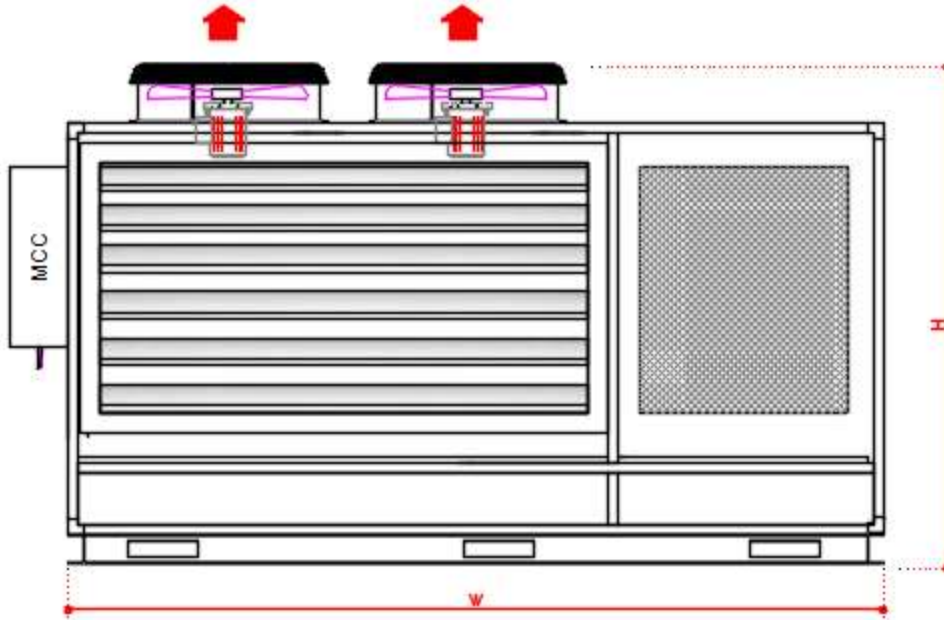
**ELEVATION**



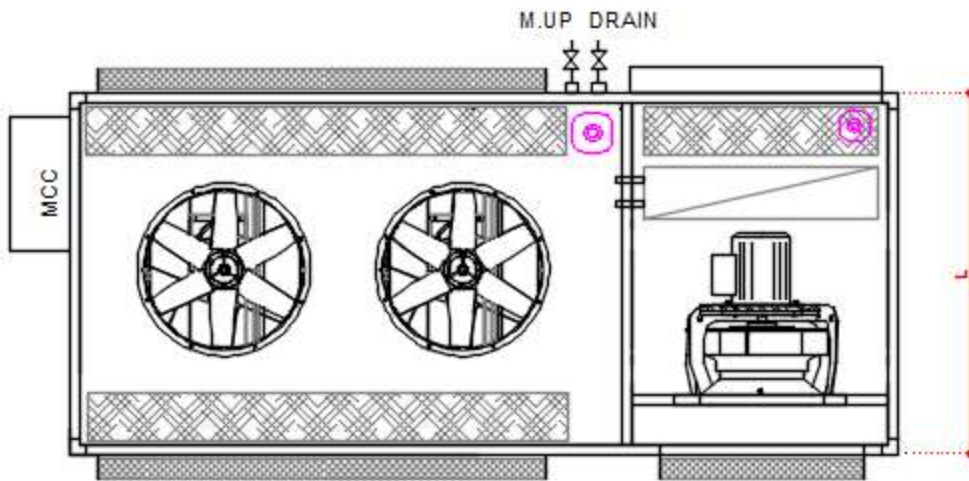
**TOP VIEW**

Model	L	W	H	M.UP	Drain	Weight
CG-MIDEC-	mm	mm	mm	Dia- mm	Dia- mm	kg
PRO-54	1600	1800	1600	25	32	380
PRO-81	1800	2100	1800	32	40	425
PRO-108	1800	2400	1800	32	40	485

Dimensional Data - Continued



**ELEVATION**



**TOP VIEW**

Model	L	W	H	M.UP	Drain	Weight
CG-MIDEC-	mm	mm	mm	Dia- mm	Dia- mm	kg
PRO-162	1800	3500	1800	40	50	525
PRO-216	1800	3500	2400	40	50	425



## **S. S. Air Technology**

Address: Karnaval Industrial Complex 3<sup>rd</sup> Industrial Zone - 6 Of October Unit # 2123

[Sales@Sma-Technology.com](mailto:Sales@Sma-Technology.com)

+201094060138

<https://www.22122.tel> ehotline